

Operators manual

V1.0 FEBRUARY 2022 EOY

 **EUROBOOR**
FOR PROFESSIONALS BY PROFESSIONALS



Mini Air Beveling Machine

BM45AIR



Congratulations on purchasing this Mini Air Beveling Machine BM45AIR. At EUROBOOR we strive to exceed our customers' expectations by developing and providing premium and innovative portable drilling and cutting solutions. We believe that a professional like you must be able to rely on a professional supplier. Which has led us to become a major player in the industrial world, with our own factory and several offices worldwide. All because we have always listened to our customers and to the demands from the market.

Our vision is focused on developing innovative portable tools that add value for our customers and facilitate them in their daily work. We never lose sight of sustainability, time savings and cost savings.

Enjoy your new machine!

Before operating your new Mini Air Beveling Machine, please first read all instructions. You find the instructions in this manual and on the warning label on your machine. With proper use, care and maintenance your machine will provide you with years of premium grinding performance.

**TO REDUCE THE RISK OF INJURY USER MUST READ AND UNDERSTAND ALL
INSTRUCTIONS**

To view all our offices and their contact information please visit: www.euroboor.com

The original manual has been produced in the English language. If any discrepancies should occur in translations, reference must be made to the original version for clarification.

Inhoudsopgave

1. Safety	4
1.1 General safety information	4
1.2 Specific safety information	7
2. Description	10
2.1 Intended use	10
2.2 Box contents	10
2.3 Description and features	11
2.4 Serial number.....	12
2.5 Technical data.....	12
2.6 Symbols.....	13
2.7 Environmental	14
3. Assembly	15
3.1 Fitting the cutting plates.....	15
3.2 Adjusting the bevel depth	16
4. Using the BM45AIR	17
4.1 Air supply system.....	17
4.2 Operating instructions	18
5. Maintenance.....	19
5.1 Normal maintenance routine	19
5.1 Oil daily	20
6. Troubleshooting.....	20
7. Exploded view & parts list	21
7.1 Exploded view.....	21
7.2 Parts list	21
7.3 Accessories	22
8. Warranty and service	23
9. Certifications.....	24
9.1 CE declaration of conformity.....	24

1. Safety

1.1 General safety information

Do not use this Mini Air Beveling Machine before you have thoroughly read and completely understood this manual, specifically the “General safety instructions” and “Specific safety information”, including the figures, specifications, safety regulations and the signs indicating DANGER, WARNING and CAUTION.

Please also observe the relevant national industrial safety regulations. Non-observance of the safety instructions in the said documentation can lead to an electric shock, burns and/or severe injuries.



WARNING: *When using the Mini Air Beveling Machine, basic safety precautions should always be followed to reduce the risk of fire, electric shock and personal injury.*



READ AND UNDERSTAND ALL SAFETY INFORMATION AND INSTRUCTIONS. *Failure to follow the warnings and instructions may result in electric shock, fire and/or serious injury.*

SAVE ALL WARNINGS AND INSTRUCTIONS FOR FUTURE REFERENCE.

This Operator’s Manual including the “General Safety Instructions” should be kept for later use and enclosed with the Mini Air Beveling Machine, should it be passed on or sold.

WORK AREA SAFETY

1. Keep your work area clean and well lit. Cluttered benches and dark areas increase the chance of accidents;
2. Do not operate the Mini Air Beveling Machine in explosive atmospheres, such as in the presence of flammable liquids, gases or dust. Mini Air Beveling Machines create sparks which may ignite the dust or fumes.
3. Keep bystanders, children, and visitors away while operating a Mini Air Beveling Machine. Distractions can cause you to lose control.

PERSONAL SAFETY



WARNING: *Wear ear and eye protection when using this Mini Air Beveling Machine.*

1. Stay alert, watch what you are doing and use common sense when using the Mini Air Beveling Machine. Do not use it while tired or under the influence of drugs, alcohol, or medication. A moment of inattention while operating the Mini Air Beveling Machine may result in serious personal injury.
2. Dress properly. Do not wear loose clothing or jewelry. Keep your hair, clothing and gloves away from moving parts. Loose clothes, jewelry, or long hair can be caught in moving parts.
3. Avoid accidental starting. Be sure that the on-/off- trigger is not pressed when plugging in the Mini Air Beveling Machine to the air supply. Carrying or plugging in the Mini Air Beveling Machine with your hands on the trigger increases the chance of accidents.
4. Never place hands, fingers, gloves or clothing near rotating tool parts.
5. Remove adjusting keys or wrench before starting the Mini Air Beveling Machine. A wrench or a key that is left attached to a rotating part of the Mini Air Beveling Machine may result in personal injury.
6. Do not overreach. Keep proper footing and balance at all times. This enables better control of the Mini Air Beveling Machine in unexpected situations.
7. Use safety equipment. Always wear eye protection. Dust mask, non-skid safety shoes, hard hat and hearing protection must be used for optimal safety.
8. If devices are provided for the connection of dust extraction and collection facilities, ensure these are connected and properly used. Use of dust collection can reduce dust-related hazards.

MINI AIR BEVELING MACHINE USE AND CARE

1. Do not force the Mini Air Beveling Machine. Use the correct machine for your application. The correct machine will do the job better and safer at the rate for which it was designed.
2. Do not use the Mini Air Beveling Machine if the switch does not turn it on or off. Any tool that cannot be controlled with the switch is dangerous and must be repaired.
3. Disconnect the air supply before making any adjustments, changing accessories, or storing Mini Air Beveling Machine. Such preventive safety measures reduce the risk of starting the Mini Air Beveling Machine accidentally.
4. Store the Mini Air Beveling Machine out of the reach of children and do not allow people who are unfamiliar with the Mini Air Beveling Machine or these instructions to operate the Mini Air Beveling Machine. Mini Air Beveling Machines are dangerous in the hands of untrained users.
5. Maintain the Mini Air Beveling Machine with care. Check for misalignment or binding of moving parts, breakage of parts, and any other condition that may affect the Mini Air Beveling Machine's operation. If damaged, have the tool serviced before use. Many accidents are caused by poorly maintained tools.
6. Keep cutting tools sharp and clean. Properly maintained tools, with sharp cutting edges are less likely to bind and are easier to control.
7. Use the Mini Air Beveling Machine and accessories in accordance with these instructions, taking into account the working conditions and the work to be performed. Use of the Mini Air Beveling Machine for operations different from those intended could result in a hazardous situation.
8. Use only accessories that are recommended by EUROBOOR for your Mini Air Beveling Machine. Accessories that may be suitable for one machine, may become hazardous when used on another machine.

SERVICE

1. Mini Air Beveling Machine service must be performed only by qualified repair personnel. Service or maintenance performed by unqualified personnel could result in risk of injury.
2. When servicing a Mini Air Beveling Machine, use only identical replacement parts. Follow instructions in the maintenance section of this manual. Use of unauthorised parts or failure to follow maintenance instructions may create a risk of electric shock or injury.



WARNING: Remove the air supply from the machine before carrying out any installation, adjustment, servicing or maintenance.

1.2 Specific safety information

1. PERSONAL SAFETY

- a) Check the air connector, air hose and machine for damage each time before using the machine
- b) Disconnect the air supply before undertaking an maintenance work on the Mini Air Beveling Machine



WARNING: *Risk of injury from high-temperature chips.*

- c) Never touch the cutting plates and keep all vulnerable body parts clear while the machine is running, as high-temperature chips are expelled at high speed during operation
- d) During operation, always guide the machine in a direction away from the body
- e) Do not use the machine above your head



WARNING: *Risk of injury to hands.*

- f) Do not reach into the processing line with your hands
- g) Use both hands to hold and operate the machine



WARNING: *Dust created by bevelling may harm your health.*

WARNING: *Never work on materials that contain asbestos.*

- h) Some types of dust, such as dust from lead-based paint, is known to cause cancer, birth defects or other reproductive harm. Risk varies on exposure and should always be reduced by working in a well-ventilated area and by making use of approved safety equipment, such as dust masks specifically designed to filter out microscopic particles



WARNING: *Only use accesory's recommended by Euroboor.*

- i) Only use recommended "cutting plates", rated at the machine's maximum cutting rate or higher
- j) Do not use dull or damaged cutting plates to prevent excessive friction and load, and thus to prevent damage to and failure of the machine
- k) Maintain labels and identification plates, as they carry important information. If unreadable or missing, obtain replacement

2. TOOL USE AND CARE



WARNING: *Not securing the workpiece properly may lead to loss of control.*

- a) Use clamps or another practical way to secure and support the workpiece to a stable platform. Holding the work by your hand or against the body leaves it unstable and may lead to loss of control.

3. RESIDUAL RISKS

In spite of the application of the relevant safety regulations and the implementation of safety devices, certain residual risks cannot be avoided.

These are:

- Impairment of hearing
- Risk of personal injury from flying particles
- Risk of burns due to accessories becoming hot during operation
- Risk of personal injury due to prolonged use.

Always try to reduce these risks as much as possible.

2. Description

2.1 Intended use

This shape bevelling and deburring tool is an air driven portable machine for machining workpieces in steel, chrome steel alloys, aluminium, aluminium alloys, brass and plastic. The machine is designed exclusively for adding bevelled edges, rounding off edges, removing burrs and removing sharp corners on workpieces. The speed of the machine is variable to suit the needs of various materials and is equipped with a graduated depth adjustable deck. It comes standard with 45° cutting plates and R1.5 radius cutting plates.



WARNING: *The machine should not be converted or modified, e.g. for any other form of use, other than as specified in these operating instructions. Warranty will be voided and the user shall be liable for damages and accidents due to incorrect use.*

2.2 Box contents

Note: *When unpacking, make sure the parts listed below are included. If missing or broken, please contact your Euroboor distributor as soon as possible.*

1 x BM45AIR Mini air beveling machine	1 x Hex key
1 x Air connector type EURO 1/4"	1 x Torx key
2 x Cutting plates 45°	1 x Oil bottle
2 x Cutting plates R1.5	1 x Instruction manual

2.3 Description and features



1. Milling head

2. Depth adjustment indicator

3. on- / off- trigger

4. Air flow regulator

5. Air exhaust

6. Air inlet

2.4 Serial number

The serial number is mentioned on the tool once: on the serial no. sticker on the Mini Air Beveling Machine. The serial number will help you, your dealer and EUROBOOR to validate and identify the power tool.







The serial number will help you and your sales point validate and identify the machine.

Maintain labels, nameplates and other machine identification. These carry important information. Obtain replacements when unreadable or missing.

2.5 Technical data

BM45AIR	Metric	Imperial
Air inlet	Ø 6.35 mm	1/4"
Air hose	Ø 9.525 mm	3/8"
Connector type	Euro type 1/4"	
Avg. Air consumption	5 SCFM (0.15 M ³ /min)	
Working pressure	6.3 bar	90 PSI
No-load speed	Max. 28.000 rpm	
Weight	320 g	0.71 Lbs
Length	150 mm	5 29/32"
Height	45 mm	1 25/32"
Max. working angle	45°	

2.6 Symbols

Symbol	Term, meaning	Explanation
	Read documentation	Be sure to read the documentation in this user manual and specifically the “General safety instructions” and “Specific safety information”.
	Wear ear protection	Use ear protection during operation.
	Wear eye protection	Use eye protection during operation.
	Danger/Warning/Caution	Read and apply the information in the adjacent text!
	European conformity symbol	Confirms the conformity of the machine with the directives of the European Community.
	ISO9001	Certified in accordance with ISO9001:2015 quality management system.
mm	Milimetre	Unit of measure for the dimensions.
“	Inch	Unit of measure for the dimensions.
Kg	Kilogram	Unit of measure for the mass.
Lbs	Pounds	Unit of measure for the mass.
Rpm	Revolutions per minute	Unit of measure for the revolutions.
SCFM	Standard cubic feet per minute	Unit of measure for air consumption.

2.7 Environmental



Separate collection. This product must not be disposed of with normal household waste.



Separate collection of used products and packaging allows materials to be recycled and used again. Re-use of recycled materials helps prevent environmental pollution and reduces the demand for raw materials.

Local regulations may provide for separate collection of electrical products from the household, at municipal waste sites or at the retailer when you purchase a new product.

3. Assembly



WARNING: Switch off and unplug the Mini Air Beveling Machine from the air supply before assembling or adjusting the tool.

3.1 Fitting the cutting plates

Note: Use both the hex key and torx key for fitting the cutting plates onto the machine.

Step 1: Loosen the two bolts that lock the guiding plate in place, using the hex key.

Step 2: Remove the guiding plate from the machine by turning it counter-clockwise.

Step 3: After removing the guiding plate, fit the cutting plates into the milling head. Use the supplied screws and torx key to tighten the cutting plates. Make sure the cutting plates are tightened properly.

Step 4: Place back the guiding plate onto the machine by rotating it clockwise. Keep rotating clockwise until the desired beveling depth is reached (3.2 adjusting the bevel depth).

Step 5: When desired beveling depth is reached, tighten the two bolts to lock the guiding plate in place, using the hex key.

Step 1



step 2



step 3



step 4



step 5

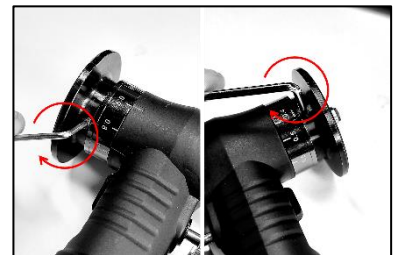

3.2 Adjusting the bevel depth

Note: For adjusting the bevel depth, the supplied hex key is required.

Step 1: Loosen the two bolts that lock the guiding plate in place, using the hex key.

Step 2: Turn the guiding plate clockwise or counter-clockwise, the bevel depth can be adjusted. The depth indicator on the side of the machine shows the set depth of the bevel. This can be set in-between 0,1 and 1,0 mm.

Step 3: Tighten the two bolts that lock the guiding plate in place, using the hex key.

Step 1

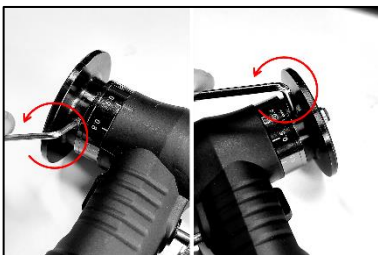

Step 2



Step 3

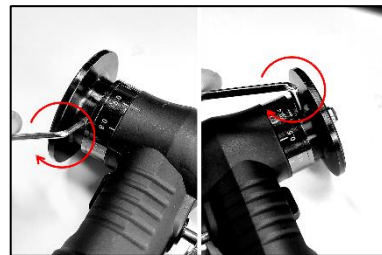

4. Using the BM45AIR

4.1 Air supply system

For using this tool the following air supply system layout is recommended:

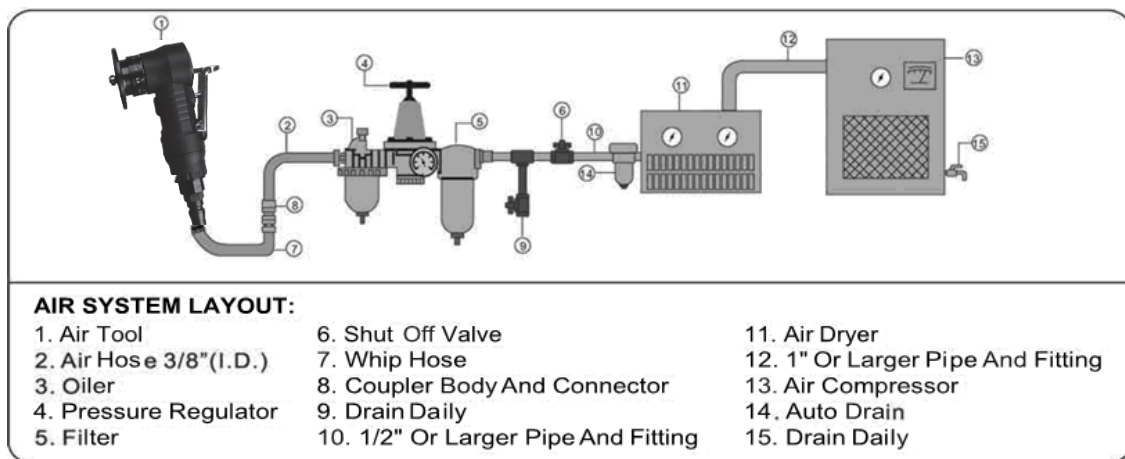

Also **take note** of the following:

- Make sure that the air compressor being used for the air tool operation supplies the correct output (SCFM).
- Have the tool in the "off" position when connecting the tool to the air supply.
- Use 90 PSI / 6 Bar air pressure while running the tool. Using a different air pressure may result in reduced performance of the Mini Air Beveling Machine.
- Drain water from the air compressor tank daily together with any condensed water in the air hoses. Water in the air supply system can result in reduced performance and/or damage.
- Clean the air inlet filter weekly. Unclean air can result in reduced performance, faster wear and/or damage.
- The minimum hose diameter should be 1/4" Inner diameter (I.D.) and the fittings should have the same inside dimensions. But usually a 3/8" I.D. air hose is recommended for air supply to get the best function of air tool operation.
- Use proper hoses and fittings and check these before each individual use.

4.2 Operating instructions

For operating the tool, please follow the steps below.

1. Lubricate the tool before operating. Please refer to “5. Maintenance”.
2. Prepare the tool, inserting the cutting plates as described in “3.1 fitting the cutting plates” and “3.2 adjusting the bevel depth”



WARNING: Only use accessory's that are recommended by Euroboor.

3. Insert the supplied air nipple into the machine.
4. Connect the air supply to the tool. Make sure the air coupling is set in place and no air is leaking.
5. Before working the tool make sure the air flow adjustment lever is set in the desired position. See [image 4-1]
6. Once the air connection is in place and the correct air flow rate has been chosen, the tool is ready to be operated. Operating the part can be done by pressing the trigger-block forward.



[image 4-1]

KEEP CLEAR THE ROTATING PARTS WITH HANDS, CLOTHES, HAIR OR ANY OTHER LOOSE OBJECTS.

Note: Lubricate the tool before operating. Please refer to “5. Maintenance”. *After lubricating the tool, let it run freely for 30 seconds in order to distribute the oil through the machine.*

7. After finishing the workpiece: Disconnect the machine from the air supply.

5. Maintenance

5.1 Normal maintenance routine

Your EUROBOOR Mini Air Beveling Machine has been designed to operate over a long period of time. Continuous satisfactory operation depends upon proper tool care and regular cleaning.



WARNING: To reduce the risk of injury, turn the Mini Air Beveling Machine off and disconnect machine from the air supply before installing and removing accessories, before adjusting or changing set-ups or when making repairs. An accidental start-up can cause injury.

Just as every tool with moving parts, your EUROBOOR Mini Air Beveling Machine also needs regular maintenance service. A few recommendations follow:

- Oil daily
- Regularly inspect all mountings and screws and ensure they are properly tightened. Should any of the screws be loose, tighten them immediately. Failure to do so may result in serious damage.
- Consult the authorised service agent about the event of failure.
- Clean the tool after each use.

5.1 Oil daily

The tool should be lubricated daily (or before each use) with air tool oil (included). During continuous operation, the tool should be oiled every 1 to 2 hours. For lubricating it is recommended to use 4 to 5 drops of oil in the air inlet. After which 30 seconds of running is required to distribute the oil through the tool.

6. Troubleshooting

Problem	Possible Cause	Corrective Action
- Tool runs slowly or will not operate	<ul style="list-style-type: none"> - No oil in tool. - Low air pressure. - Air hose leaks. - Pressure drops - Moisture blowing out of tool exhaust. - Worn rotor blade. 	<ul style="list-style-type: none"> - Lubricate the tool with EUROBOOR pneumatic oil IBO.80. - Adjust the compressor regulator to 90 PSI and/or Adjust the regulator on the tool to maximum setting. - Check the air hose for possible leaks and repair these. Be sure the hose is the proper size. - Do not use a multiple number of hoses connected together with quick-connect fittings. - Water in tank: drain tank. Oil tool and run until no water is evident. Oil tool again and run 1-2 seconds.
- Abnormal vibration and/or excessive heat	- Improper lubrication.	- Lubricate the tool with EUROBOOR pneumatic oil IBO.80.

For any problems not in this troubleshooting table, contact your EUROBOOR distributor or sales agent from whom purchased the tool.

7. Exploded view & parts list

7.1 Exploded view

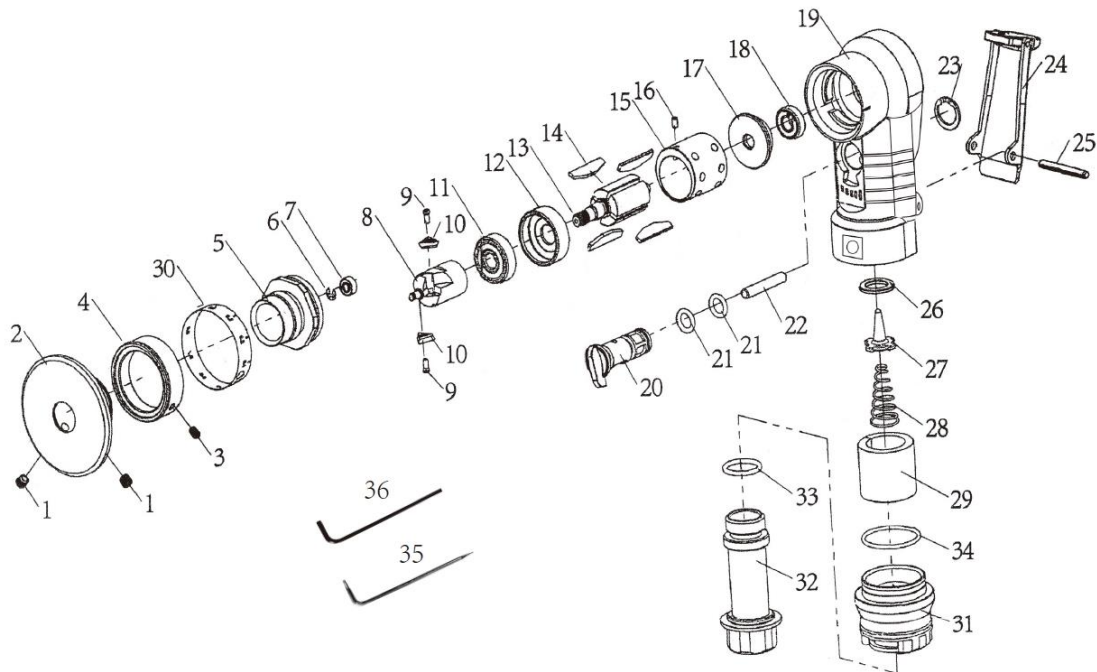





7.2 Parts list

No.	Description	Qty	No.	Description	Qty
1	Guiding plate screw M4	2	18	Ball bearing (695ZZ)	1
2	Guiding plate	1	19	Housing	1
3	Depth indicator screw M3	1	20	Adjustment valve	1
4	Depth indicator	1	21	O-ring	2
5	Lock screw	1	22	Pin	1
6	E-ring	1	23	Ring	1
7	Ball bearing (683ZZ)	1	24	On- / off- trigger	1
8	Shank	1	25	Spring pin	1
9	Cutting plate screw	2	26	Washer	1
10	Cutting plate for steel (45°)	2	27	Valve	1
10	Cutting plate for Aluminum (45°)	2	28	Valve spring	1
10	Cutting plate for stainless steel (45°)	2	29	Silencer pad	1
10	Cutting plate for steel (radius R1.5)	2	30	Label	1
11	Ball bearing (626ZZ)	1	31	Exhaust sleeve	1
12	Front end plate	1	32	Air inlet housing	1
13	Rotor	1	33	O-ring	1
14	Rotor blade	4	34	O-ring	1
15	Cylinder	1	35	Hex key	1
16	Spring pin	1	36	Torx key	1
17	Rear end plate	1			

7.3 Accessories

For the BM45AIR EUROBOOR only has consumables on stock available. The consumables for this machine are the different types of cutting plates, and the oil. Please see below the EUROBOOR searchcodes for these items.

Ordering these items can be done at your nearest EUROBOOR dealer.

Image	Description	Searchcode
No image available	Screw for cutting plate	BM45AIR.0009
	Cutting plate for steel (45°)	BM45AIR.45ST
	Cutting plate for aluminium (45°)	BM45AIR.45ALU
	Cutting plate for Stainless steel (45°)	BM45AIR.45SS
	Cutting plate radius 1.5 (R1.5)	BM45AIR.R1.5
No image available	Air tool Oil	IBO.80

8. Warranty and service

Warranty

Euroboor B.V. warrants this machine to be free of material defects and workmanship errors under normal use for a period of 12 months after date of purchase.

Serial number:

Date of purchase:

Service

To maximise the lifetime of your EUROBOOR machine always use service and parts from an official EUROBOOR distribution channel. Whenever in need of such, always contact original point of sales or if no longer existent the distributor of EUROBOOR products in your country.

9. Certifications

9.1 CE declaration of conformity

EUROBOOR BV declares that the following appliance complies with the appropriate basic safety and health requirements of the EC guidelines based on its design and type, as brought into circulation by EUROBOOR BV.

Designation/function	Pneumatic chamfering machine
Brand	EUROBOOR
Types	BM45AIR
Ratings and principal	6.3 bar / 90 PSI – 5 SCFM (0.15 M ³ /min) Speed: 28.000 rpm max.
Applicable guidelines	Machinery Directive 2006/42/EC
Used test standards	EN ISO 12100:2010, EN 60204-1:2018
Certificate ref. No.	M.2022.206.C71198
Testing laboratory:	UDEM International Certification Auditing Training Centre
Date issued:	17.02.2022

Zoetermeer, 21 February 2022

Albert Koster



Managing Director