

Operators manual

V 1.0 | EN | April 2022

 **EUROBOOR**
FOR PROFESSIONALS BY PROFESSIONALS



Dry Cut-Off Metal Saw

14" / 355 mm

EDC.355



Congratulations on the purchase of your EUROBOOR EDC.355 Dry Cut-Off Metal Saw. At EUROBOOR we strive to exceed our customers' expectations by developing and providing premium and innovative portable drilling and cutting solutions. We believe that a professional like you must be able to rely on a professional supplier. Which has led us to become a major player in the industrial world, with our own factory and several offices worldwide. All because we have always listened to our customers and to the demands from the market.

Our vision is focused on developing innovative portable tools that add value for our customers and facilitate them in their daily work. We never lose sight of sustainability, time savings and cost savings.

Enjoy your new machine!

Before operating your dry cutting machine, please read all instructions first. These include the Operators Manual and warning label on the unit itself. With proper use, care and maintenance your model will provide you with years of effective metal cutting performance.

TO REDUCE THE RISK OF INJURY USER MUST READ AND UNDERSTAND ALL INSTRUCTIONS

To view all our offices and their contact information please visit: www.euroboor.com

The original manual has been produced in the English language. If any discrepancies should occur in translations, reference must be made to the original version for clarification.

Table of contents

Table of contents	3
1. Safety	4
1.1 General safety instructions	4
1.2 Specific safety information.....	8
2. Description	10
2.1 intended use.....	10
2.2 Description and features.....	11
2.3 Box contents.....	12
2.4 Serial number	12
2.5 Technical data	13
2.6 Symbols	14
2.7 Environmental	15
3. Preparation & adjustment.....	16
3.1 Assembly	16
3.2 Prior to use	16
3.3 Fitting the blade	18
3.4 Replacing the blade	19
3.5 Setting cutting angle.....	21
3.6 Clamping the workpiece.....	22
3.7 Adjusting cutting depth.....	24
4. Using the machine	25
4.1 Turning the motor on and off.....	25
4.2 Restart mid-cut.....	26
4.3 Carrying the machine	26
5. Maintenance.....	27
6. Troubleshooting.....	29
7. Exploded view & Partslist.....	30
7.1 Exploded view	30
7.2 Spare parts list.....	32
8. Warranty and service	35
9. Certifications.....	36
9.1 CE declaration of conformity.....	36
9.2 Intertek proof of certification	37

1. Safety

1.1 General safety instructions



WARNING: *When using the Dry Cut-Off Metal Saw, basic safety precautions should always be followed to reduce the risk of fire, electric shock and personal injury.*



READ AND UNDERSTAND ALL SAFETY INFORMATION AND INSTRUCTIONS. *Failure to follow the warnings and instructions may result in electric shock, fire and/or serious injury.*

SAVE ALL WARNINGS AND INSTRUCTIONS FOR FUTURE REFERENCE

This Operator's Manual including the "General Safety Instructions" should be kept for later use and enclosed with the power tool, should it be passed on or sold.

The term "power tool" in the warnings refers to your mains-operated corded power tool.

Please also observe the relevant national industrial safety regulations. Non-observance of the safety instructions in the said documentation can lead to an electric shock, burns and/or severe injuries.

WORK AREA SAFETY

1. Keep your work area clean and well lit. Cluttered benches and dark areas increase the chance of accidents;
2. Do not operate power tools in explosive atmospheres, such as in the presence of flammable liquids, gases or dust. Power tools create sparks which may ignite the dust or fumes.
3. Keep bystanders, children, and visitors away while operating a power tool. Distractions can cause you to lose control.

ELECTRICAL SAFETY



DANGER

1. Power tool plugs must match the outlet. Never modify the plug in any way. Do not use any adapter plugs. Unmodified plugs and matching outlets will reduced risk of electric shock.
2. Avoid body contact with grounded surfaces such as pipes, radiators, ranges and refrigerators. There is an increased risk of electric shock if your body is earthed or grounded.
3. Do not expose power tools to rain or wet conditions. Water entering a power tool will increase the risk of electric shock.
4. Do not abuse the cord. Never use the cord to carry the power tool or pull the plug from an outlet. Keep cord away from heat, oil, sharp edges or moving parts. Replace damaged cords immediately. Damaged cords increase the risk of electric shock.
5. When operating a power tool outdoors, use an extension cord suitable for outdoor use. Use of a cord suitable for outdoor use reduces the risk of electric shock.
6. If operating a power tool in a damp location is unavoidable, use a residual current device (RCD) protected supply. Use of an RCD reduces the risk of electric shock.

PERSONAL SAFETY



WARNING: *Wear ear and eye protection when using this power tool.*

1. Stay alert, watch what you are doing and use common sense when using a power tool. Do not use machine while tired or under the influence of drugs, alcohol, or medication. A moment of inattention while operating power tools may result in serious personal injury.
2. Use personal protective equipment. Always wear eye protection. Protective equipment such as dust mask, non-skid safety shoes, hard hat, or hearing protection used for appropriate conditions will reduce personal injuries.
3. Prevent unintentional starting. Ensure switch is in the off-position before connecting to power source and/or battery pack, picking up or carrying tool. Carrying power tools with your hand on the switch or energising power tools while pressing the switch, invites accidents.
4. Remove any adjusting key or wrench before turning the power tool on. A wrench or a key that is left attached to a rotating part of the tool may result in personal injury.
5. Do not overreach. Keep proper footing and balance at all times. This enables better control of the power tool in unexpected situations.
6. Dress properly. Do not wear loose clothing or jewellery. Keep your hair, clothing, and gloves away from moving parts. Loose clothes, jewellery, or long hair can be caught in moving parts.
7. If devices are provided for the connection of dust extraction and collection facilities, ensure these are connected and properly used.
8. Never place hands, fingers, gloves or clothing near cutting area or rotating machine parts.

POWER TOOL USE AND CARE

1. Secure your workpiece properly. The workpiece should be clamped to avoid possible movement and pinching as the cut nears completion.
2. Do not force the power tool. Use the correct power tool for your application. The correct power tool will do the job better and safer at the rate for which it was designed.
3. Do not use the power tool if the switch does not turn it on or off. Any tool that cannot be controlled with the switch is dangerous and must be repaired.
4. Disconnect the plug from the power source before making any adjustments, changing accessories, or storing power tools. Such preventive safety measures reduce the risk of starting the power tool accidentally.

5. Store power tools out of the reach of children and do not allow person unfamiliar with the power tool or these instructions to operate the power tool. Power tools are dangerous in the hands of untrained users.
6. Maintain power tools. Check for misalignment or binding of moving parts, breakage of parts, and any other condition that may affect the power tool's operation. If damaged, have the tool serviced before use. Many accidents are caused by poorly maintained tools.
7. Keep cutting tools sharp and clean. Properly maintained tools, with sharp cutting edges are less likely to bind and are easier to control.
8. Use the power tool, accessories and tool bits, etc. in accordance with these instructions, taking into account the working conditions and the work to be performed. Use of the power tool for operations different from those intended could result in a hazardous situation.
9. Use only accessories that are recommended by EUROBOOR for your power tool. Accessories that may be suitable for one machine, may become hazardous when used on another power tool.

SERVICE

1. Power tool service must be performed only by qualified repair personnel. Service or maintenance performed by unqualified personnel could result in risk of injury.
2. When servicing a power tool, use only identical replacement parts. Follow instructions in the maintenance section of this manual. Use of unauthorised parts or failure to follow maintenance instructions may create a risk of electric shock or injury.

RESIDUAL RISKS

In spite of the application of the relevant safety regulations and the implementation of safety devices, certain residual risks cannot be avoided.

- Impairment of hearing
- Risk of personal injury from flying particles
- Risk of burns due to accessories becoming hot during operation
- Risk of personal injury due to prolonged use.

Always try to reduce these risks as much as possible.

1.2 Specific safety information



WARNING: *This tool is intended to function as Dry Cut-Off Metal Saw. Read all safety warnings, instructions, illustrations and specifications provided with this tool. Failure to follow all instructions listed below may result in electrical shock, fire and serious injury.*

Safety instructions

1. Fully assemble your metal cutting saw before operation.
2. Secure your workpiece properly. Work should be clamped to avoid possible movement and pinching as the cut nears completion.
3. Please do the following safety checks before you start using the machine.
 - a. Always check if all bolts, screws and clamps are fully tightened. Tighten loose bolts before use. If bolts, screws or clamps are missing, please refer to your EUROBOOR dealer and have these replaced.
 - b. Always check if the blade can run freely before you start working with the machine. Have the Dry Cut-Off Metal Saw serviced by qualified repair personnel at your EUROBOOR dealer, if the blade cannot run freely or vibrates heavily.
 - c. Check the blade for cracks or other damage before operation. Do not use blade when it is damaged or deformed.
 - d. Check if your workpiece is properly secured, using the machine's clamp.
 - e. Check if the blade of the machine is not contacting the workpiece before the machine is turned on.
4. Turn the machine on, but allow the motor to come up to full speed before you start cutting.
5. Lower the blade onto the material firmly.
6. Wait for the blade to come to a full stop before making adjustments to the machine or removing / securing the workpiece.
7. Always shut off and unplug machine before servicing or adjusting the machine.
8. Save the instructions manual and warning labels at all times.

Safety warnings

1. **Do not** operate your metal cutting saw until it is completely assembled and installed according to the instruction.
2. **Do not** operate your metal cutting saw when bolts, screws and clamps are missing or not fully tightened.
3. **Do not** operate the machine if you are not familiar with the operation of a metal cutting saw. Please obtain advice from a qualified person.
4. **Do not** use the machine in area's with flammable liquids or gasses.
5. **Do not** use the machine in damp area's or when it is exposed to rain.
6. **Do not** use the machine if the blade cannot run freely or vibrates heavily.
7. **Do not** reach behind or over the cutting tool when it is connected to the power source.
8. **Do not** reach your hands in or near the path of the saw blade.
9. **Do not** cut any objects that are not clamped, using the clamp of the dry cutting machine.
10. **Do not** make any adjustments to the machine, removing or securing the workpiece, when the blade has not come to a full stop.
11. **Do not** use a sawing blade with a larger outer diameter than the machines maximum of 355 mm (14").
12. **Do not** remove any guards from the machine, as they contribute to the safety level of the machine.
13. **Do not** allow the blade to chatter and jump as this may cause increased wear on the blade, resulting in poor cutting and possible broken blade teeth.

2. Description

2.1 intended use

This EUROBOOR EDC.355 Dry Cut-Off Metal Saw is an electrically driven machine for cutting various types of ferrous and non-ferrous metals. The machine is designed to fit a 355 mm (14") blade. The speed of the machine is 1,450 RPM, with soft-start. The machine has an extra safety button to prevent accidental starts. For cutting, the machine can be adjusted from 0° to 45° corners. Also the dept can be adjusted using the depth-adjustment screw.



WARNING: *The machine should not be converted or modified, e.g. for any other form of use, other than as specified in these operating instructions. Warranty will be voided and the user shall be liable for damages and accidents due to incorrect use.*

2.2 Description and features

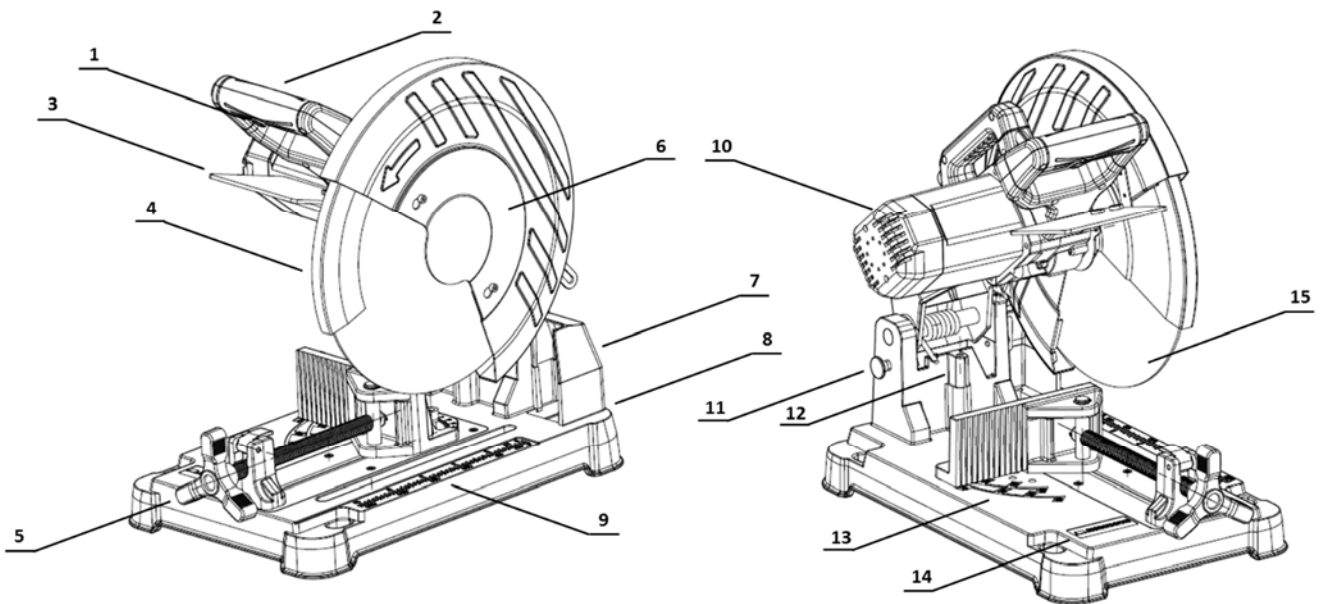

[Image 2-1]

Refer to [Image 2-1] for the following features of the machine EDC.355.

- | | |
|----------------------------|--|
| 1. Safety button | 9. Aluminium base with size indication |
| 2. On- / off trigger | 10. Engine cover / air intake |
| 3. Hand protection shield | 11. Arm lock pin |
| 4. Retractable blade cover | 12. Depth adjustment screw |
| 5. Clamp knob | 13. Angle indication |
| 6. Spindle cover | 14. Brand label |
| 7. Dust cover | 15. Sawblade |
| 8. Dust collection tray | |

2.3 Box contents

Note: *When unpacking, make sure the parts listed below are included. If missing or broken, please contact distributors as soon as possible.*

1x Machine EDC.355

1x Instruction manual

1x Hexagon key M6

1x Hexagon key M10

2x Spare carbon brushes

2.4 Serial number

The serial number is mentioned on the machine twice: on the motor and base. The serial number will help you and your sales point validate and identify the machine.

For example:

3552204001

Breaks down to:

355

22

04

001

Machine

Year

Month







Identification number

Maintain labels, name plates and other machine identification. These carry important information. Obtain replacements when unreadable or missing.









2.5 Technical data

EDC.355	Metric	Imperial
Folded dimensions (L x W x H)	530 x 350 x 420 mm	20 7/8 x 13 3/4 x 16 9/16"
Unfolded dimensions (L x W x H)	620 x 350 x 630 mm	24 7/16 x 13 3/4 x 24 13/16"
Weight	18.6 kg	41 lb
Motor power	2,480 W	11 A
Speed	1,450 rpm	
Max. blade diameter	355 mm	14"
Bore diameter	25.4 mm	1"
Max. cutting angle	45°	
Voltage	230 V 50/60 Hz	120 V 60 Hz

2.5.1 Cutting capacities

EDC.355	Metric	Imperial
Cutting capacity 0° 	105 x 105 mm	4 1/8 x 4 1/8"
Cutting capacity 0° 	90 x 145 mm	3 9/16 x 5 11/16"
Cutting capacity 0° 	120 mm	4 3/4"
Cutting capacity 45° 	80 x 80 mm	3 1/8 x 3 1/8"
Cutting capacity 45° 	90 x 80 mm	3 9/16 x 3 1/8"
Cutting capacity 45° 	90 mm	3 9/16"

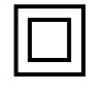
2.6 Symbols

Symbol	Term, meaning	Explanation
	Read documentation	Be absolutely sure to read the enclosed documentation such as the Instruction Manual and the General Safety Instructions
	Wear ear protection	Use ear protection during operation
	Wear eye protection	Use eye-protection during operation
	Dangerous electrical voltage	Be sure the machine is safe for use, without any open and/or protruding wires
	Danger/warning/caution	Observe the information in the adjacent text!
	European conformity symbol	Confirms the conformity of the power tool with the directives of the European Community
	ISO9001	Certified in accordance with ISO9001:2015 quality management system.
	Class of protection II	Product with double layered insulation. In case of failure of the main layer of insulation the product remains safe due to a second layer of insulation.
	Intertek	Licensed testing laboratory for CE certification
	cETLus listed mark	The product is approved for selling on the Canadian and US markets.
mm	Millimetre	Unit of measure for the dimensions
"	Inch	Unit of measure for the dimensions

Symbol	Term, meaning	Explanation
kg	Kilogram	Unit of measure for the mass
lb	Pound	Unit of measure for the mass
V	Volt	Unit of measure for the electric voltage
A	Ampere	Unit of measure for the electric current intensity
W	Watt	Unit of measure for the output
rpm	Revolutions per minute	Unit of measure for the motor speed

2.7 Environmental



Separate collection. This product must not be disposed of with normal household waste.



Separate collection of used products and packaging allows materials to be recycled and used again. Re-use of recycled materials helps prevent environmental pollution and reduces the demand for raw materials.

Local regulations may provide for separate collection of electrical products from the household, at municipal waste sites or by the retailer when you purchase a new product.

3. Preparation & adjustment

3.1 Assembly

The EUROBOOR EDC.355 machine comes pre-assembled, but without blade attached. Fitting the blade to the machine is necessary before operating the machine. Please refer to “3.3 fitting the blade” for instructions on how to fit the blade. Further to this it is advised to check the machine is complete and all standard accessories are included before proceeding in any way.



WARNING: *Before undertaking any type of preparation or adjustment, make sure the machine is switched off and the power supply is disconnected.*

3.2 Prior to use

Prior to any use, check the machine and all of its components for damage and check that all moving parts are in perfect working order and do not jam.

All parts must be correctly installed and must fulfil all conditions necessary to ensure perfect operation of the machine.

A damaged and/or incorrectly functioning machine must be repaired or replaced according to the original specifications by EUROBOOR or any authorised EUROBOOR dealer or service point.

DO NOT use under wet conditions or in presence of flammable liquids or gases.

DO NOT let children come into contact with the machine. Supervision is required when inexperienced operators use this machine.

ELECTRICAL SAFETY

The machine electronics have been designed for one voltage only. Always check that the power supply corresponds to the voltage on the rating label.

EUROBOOR EDC.355 is designed in class II (double isolated). Earth grounding is not required.

If the power supply cord is damaged, it must be replaced by a specially prepared cord available through the EUROBOOR service organisation.

EXTENSION CABLE

If an extension cable is required, use an approved extension cable suitable for the power input of this tool (see technical data). The minimum conductor size is 1.5 mm²; the maximum length is 30 meter. When using a cable reel, always unwind the cable completely.

3.3 Fitting the blade



WARNING: Before undertaking any type of preparation or adjustment, make sure the machine is switched off and the power supply is disconnected.

1. Remove the spindle cover by loosening the two bolts using the M6 hexagon key.
2. Put on the spindle lock by using the spindle lock lever. Carefully rotate the spindle, by hand, until the spindle lock locks in place.

After the spindle is locked, keep the lock on and at the same time, loosen the spindle bolt using the M10 hexagon key.

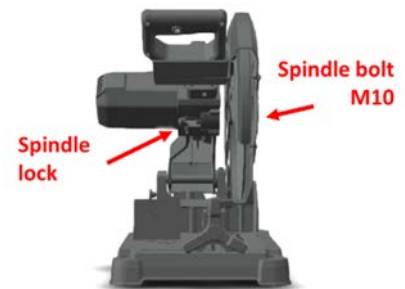

3. When the spindle bolt is loosened: remove the small flange and the front-flange from the driveshaft.

Note: Keep the back-flange in place.

4. Raise the retractable blade cover to its highest position. While remaining in that position, the sawing blade can be placed onto the spindle.

Note: Check the blade for cracks or other damage before operation. Do not use blade when it is damaged or deformed. Also check if the blade can run freely and without vibrating.



5. Lower the retractable blade cover and put the front-flange and small flange back into place.
6. Tighten the spindle bolt using the M10 hexagon key. Make sure the spindle is locked using the spindle lock while tightening the spindle bolt.
7. Put the spindle cover back in place and tighten the bolts using the M6 hexagon key.

3.4 Replacing the blade

WARNING: Before undertaking any type of preparation or adjustment, make sure the machine is switched off and the power supply is disconnected.

1. Remove the spindle cover by loosening the two bolts using the M6 hexagon key.



2. Put on the spindle lock by using the spindle lock lever. Carefully rotate the blade, by hand, until the spindle lock locks in place.

After the spindle is locked, keep the lock on and at the same time, loosen the spindle bolt using the M10 hexagon key.



3. When the spindle bolt is loosened: remove the small flange and the front-flange from the driveshaft.

Note: *Keep the back-flange in place*

4. Raise the retractable blade cover and take out the current blade.



WARNING: *Be careful for sharp edges.*

5. With the retractable blade cover still held in raised position, the new sawing blade can be placed onto the spindle.

Note: *Check the blade for cracks or other damage before operation. Do not use blade when it is damaged or deformed. Also check if the blade can run freely and without vibrating.*

6. Lower the retractable blade cover and put the front-flange and small flange back into place.
7. Tighten the spindle bolt using the M10 hexagon key. Make sure the spindle is locked using the spindle lock while tightening the spindle bolt.
8. Put the spindle cover back in place and tighten the bolts using the M6 hexagon key.

3.5 Setting cutting angle

The EUROBOOR EDC.355 has the capability to make cuts from 0° to 45° angles. Be sure that the correct angle is set before you start working with the machine. For setting the correct angle, follow below steps and refer to the image below:

1. Loosen the 'angle lock screw' using the angle lock lever. By turning the angle lock lever (1) counter-clockwise the screw will be loosened. By lifting the angle lock lever slightly and moving it back clockwise, the screw can be loosened even further.
2. After loosening the 'angle lock screw' tilt up the 'angle lock pin' (2), turn it a quarter which locks the pin in the raised position.
3. The cutting angle can be adjusted by moving the plate to the desired position (3). Use the angle indication engraved in the base for your reference.
4. After setting the plate in the desired position, have the 'angle lock pin' (4) fall back in place, and tighten the 'angle lock screw' by turning the angle lock lever (5) clockwise.

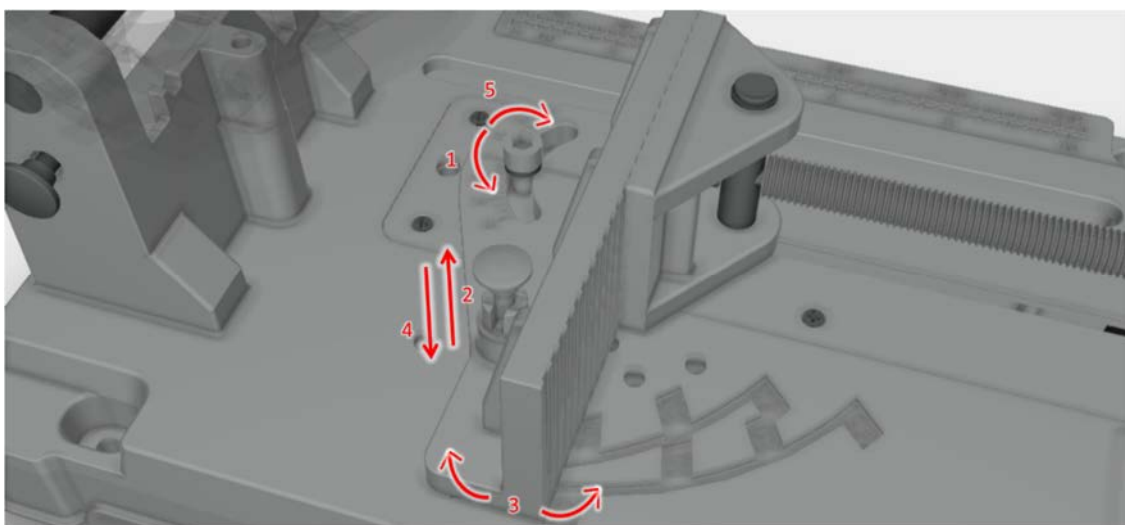

3.6 Clamping the workpiece

When the correct angle is chosen for the workpiece, be sure to tighten the workpiece properly. The workpiece must be tightened before cutting to avoid possible movement and pinching of the workpiece as the cut nears completion.

For clamping the workpiece, follow below steps:

1. After setting the correct cutting angle. Unlock the 'quick lock and release lever' (1) by tilting it backwards, and pull back the clamp from the plate (2).
2. Place the workpiece between the plate and clamp.
3. Push the clamp against the workpiece (3).
4. When the clamp is against the workpiece, Put the 'quick lock and release lever' (4) back in its original position. Tighten the workpiece by turning the clamp knob clockwise (5).

Note: For releasing the workpiece from a pressured position, first turn the clamp knob counter-clockwise to remove pressure from the workpiece. Then unlock the 'quick lock and release lever' and pull back from the workpiece.

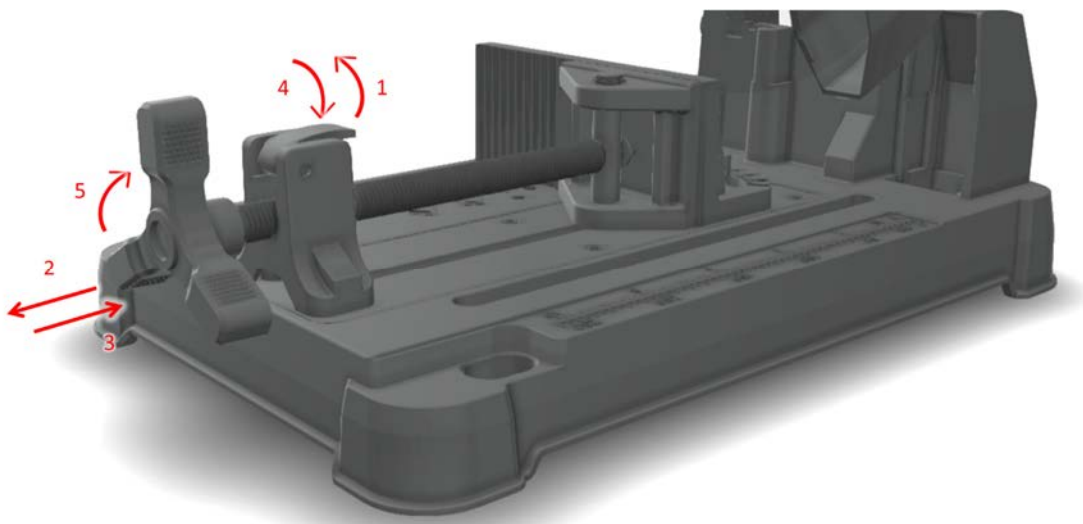

3.6.1 Adjusting the plate positioning.

Note: make sure the workpiece is centred with the sawblade. For bigger workpieces, the positioning of the plate should be in position 2.

The plate can be positioned in two different positions. The position 1 is suitable for workpieces of maximum 150 mm, position 2 is suitable for workpieces of up to 180mm.

Changing between these positions can be done in the following steps:

1. Fully loosen all screws that lock the plate.
2. After all screws are loosened completely, pull out and lock the “angle lock pin”.
3. The plate can be replaced in the other position now.
4. When placed in the new position, fully tighten all screws again and lock the “angle lock pin”.

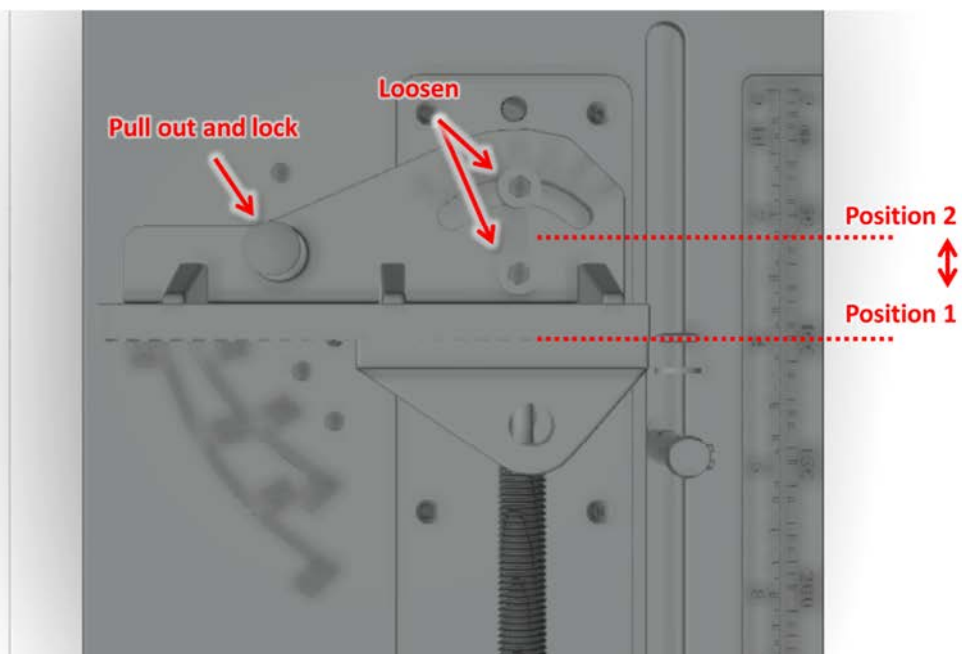

3.7 Adjusting cutting depth

The maximum depth of cutting can be adjusted by turning the depth adjustment bolt clockwise or counter clockwise. When depth is set to the right value, this bolt prevents the blade to touch the surface under the base.

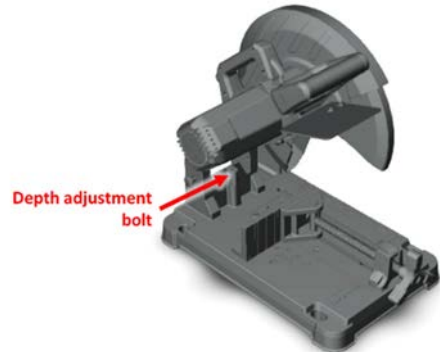

3.7.1 Increase depth of cut

To increase the depth of cut, loosen the depth adjustment bolt (by turning it counter clockwise), then rotate the nut in clockwise direction until it is fully tightened.

3.7.2 Reduce depth of cut

To reduce the depth of cut, rotate the nut in counter clockwise direction firstly, then tighten the depth adjustment bolt (by turning it clockwise) until it is fully tightened.

4. Using the machine

4.1 Turning the motor on and off

The machine is provided with an additional safety button that prevents accidental starting. Follow below steps to safely operate the machine.

1. Make sure all adjustments to the machine have been done and the workpiece is tightened onto the machine properly.
2. Plug in the machine.
3. Press the safety button and hold it. Then press the on-/off trigger.
4. The machine will start running now. Allow the motor to reach full speed.
5. Check if the blade runs freely and is not vibrating. If the blade cannot run freely or is vibrating heavily, stop immediately and refer to your EUROBOOR dealer.
6. Slowly lower the blade onto the workpiece and cut through firmly. Do not force the machine or put too much pressure as this will only shorten the lifetime of the blade and increase wear on the machine.
7. When the workpiece is finished, raise the wheel completely and release the on-off trigger. Wait for the blade to come to a complete stop before collecting the workpiece or making any adjustments to the machine.

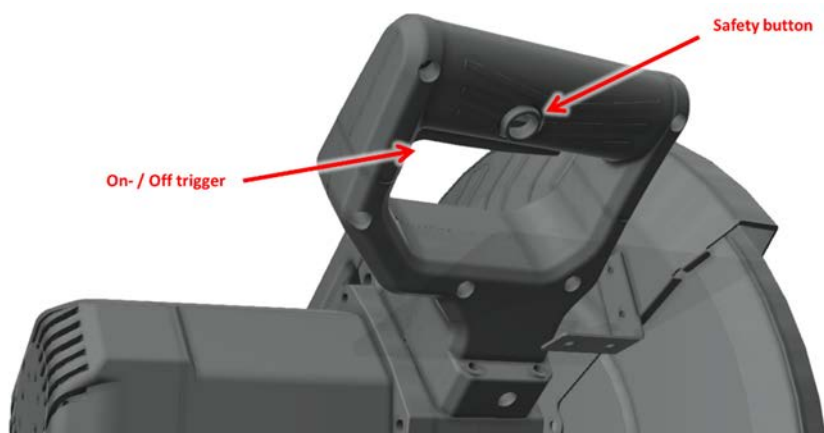

Note: After cutting the workpiece can have sharp or hot edges. Be careful collecting the workpiece from the machine.

4.2 Restart mid-cut

If the machine is stopped during cutting, release the trigger and remove the blade from the workpiece. When in fully raised position, start the machine again and slowly lower the blade on the workpiece. The work can now be resumed. Do not force the machine, this will increase wear on the blade and machine.

4.3 Carrying the machine

Note: Only carry the machine with arm folded down (Locked). For (un)locking the arm in the lowered position, follow the steps below.

Note: When the blade is carried separately from the machine, make sure the blade is in its box/holder to prevent injuries from sharp edges.



Lock the arm in lowered position.

1. Lower the machine's arm, and keep it in the fully lowered position.
2. While in lowered position, press the lock pin. The lock pin will lock the arm in lowered position.
3. Now the machine is ready to be carried. Carry the machine using the handle on top.

Unlock the arm from its lowered position

1. Only unlock the arm from the lowered position after the machine is standing stable on its designated position.
2. Unlock the arm by pulling out the lock pin from the machine.
3. Firmly raise the machine's arm. The arm is now in working position.

5. Maintenance

Your EUROBOOR power tool has been designed to operate over a long period of time with a minimum of maintenance. Continuous satisfactory operation depends upon proper tool care and regular cleaning.



CAUTION: *To reduce the risk of injury, turn off and disconnect the machine from the power source before installing and removing accessories, before adjusting or changing set-ups or when making repairs.*

Just as every power tool with moving parts, your EUROBOOR EDC.355 also needs regular maintenance.

VISUALLY CHECK THE MACHINE FOR DAMAGE

Machine must be checked before operation for any signs of damage that will affect the operation of the machine. Particular notice must be taken of the mains cable, switches and moving parts. If the machine appears to be damaged it should not be used. Failure to do so may cause injury or death.

CLEANING

- Clean all dirt, dust, metal chips and burrs from the machine regularly. The use of compressed air is advised. Never remove metal chips with bare hands!
- Blow dirt and dust out of the motor housing with compressed air as often as dirt is seen collecting in and around the air vents. Wear approved eye protection and an approved dust mask.
- Never use solvents or other harsh chemicals for cleaning the non-metallic parts of the tool. These chemicals may weaken the materials used in these parts. Use a cloth dampened only with water and mild soap. Never let any liquid get inside the tool; never immerse any part of the tool into a liquid.

- Take out the dust collection tray and empty it. Be sure to put the dust collection tray back in place before you start working with the machine again.

OPERATION OF THE MACHINE

The machines operation must be checked to ensure that all components are working correctly. Replace any defective parts immediately. This prevents properly function parts from being damaged.

REPAIR, MODIFICATION AND INSPECTION

Repair, modification and inspection of EUROBOOR EDC.355 must be done by EUROBOOR or an EUROBOOR authorised dealer. The spare parts list will be helpful if presented with the machine to the EUROBOOR dealer for service when requesting repair or other maintenance.

EUROBOOR machines are constantly being improved and modified to incorporate the latest technological advancements. Accordingly, some parts (i.e. part numbers and/or design) may be changed without prior notice. Also, due to EUROBOOR's continuing program of research and development, the specifications of machines are subject to change without prior notice.



WARNING: *Since accessories, other than those offered by EUROBOOR, have not been tested with this product, use of such accessories with this tool could be hazardous. To reduce the risk of injury, only EUROBOOR recommended accessories should be used with this product. Consult your dealer for further information on the appropriate accessories.*

6. Troubleshooting

Motor does not start	<ul style="list-style-type: none"> - Replace carbon brushes - Check the power supply
Motor stalls	<ul style="list-style-type: none"> - Replace carbon brushes - Check the power supply - Put less pressure on the machine while cutting
The blade hits the base	<ul style="list-style-type: none"> - Decrease the depth of cut - Check if the blade is fitted to the machine properly - Check machine for any signs of misalignment
The cut is not straight	<ul style="list-style-type: none"> - Check the cutting blade for damages or vibrations - Check the positioning of the workpiece - Put less pressure on the machine while cutting
Retractable blade cover does not fully open or close	<ul style="list-style-type: none"> - Defective spring or connection rod - Blade not fitted properly - Blade not the right size (too big)
Rough cuts	<ul style="list-style-type: none"> - Put less pressure on the machine while cutting - Worn blade (replace blade) - Not the correct blade for the application
Machine vibrates or shakes	<ul style="list-style-type: none"> - Sawblade damaged - Sawblade not straight - Sawblade not fitted properly - Sawblade not tightened properly - Machine misaligned

When a problem that occurs cannot be solved using the scheme above, please refer to your EUROBOOR dealer.

7. Exploded view & Partslist

7.1 Exploded view

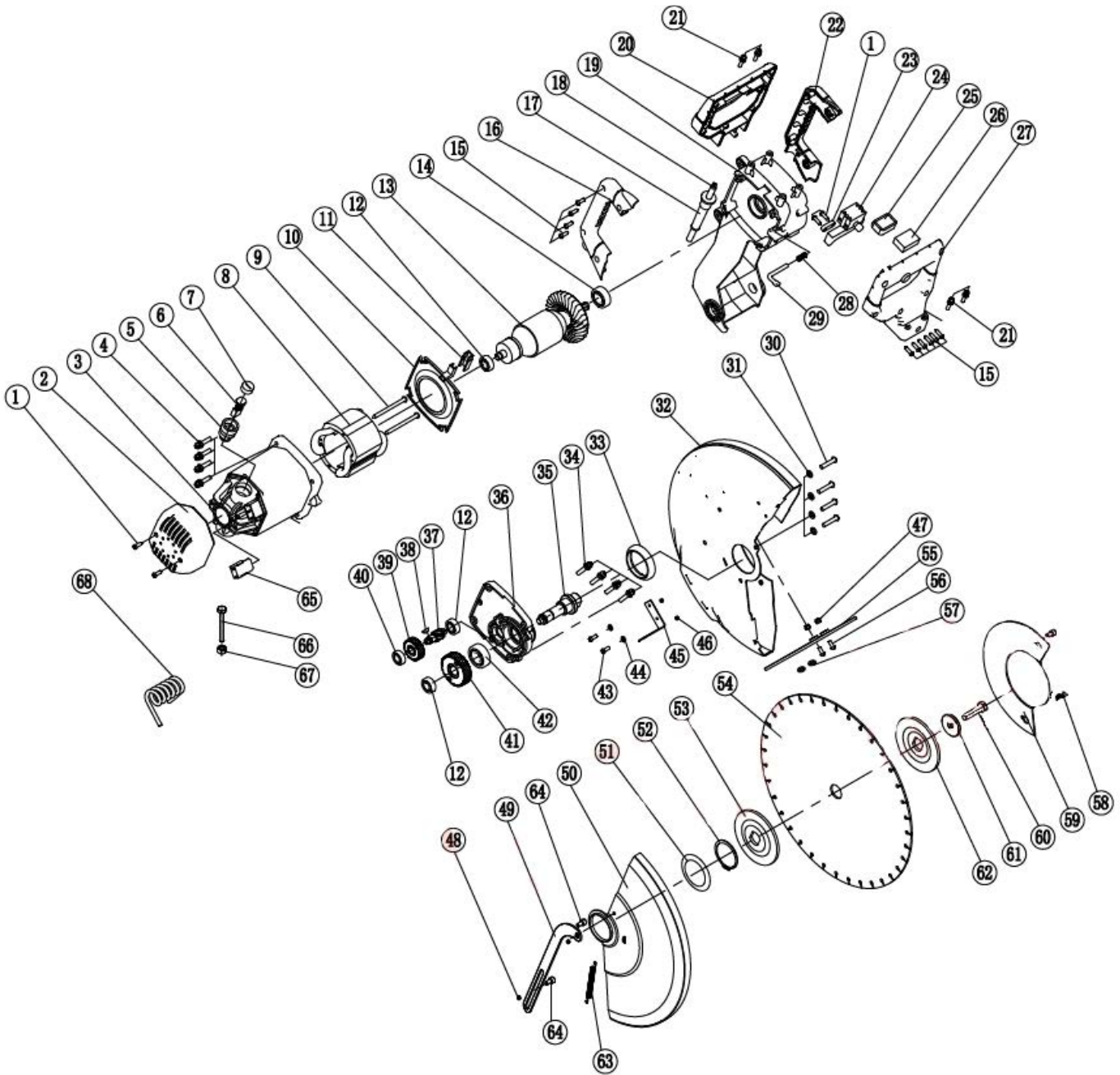

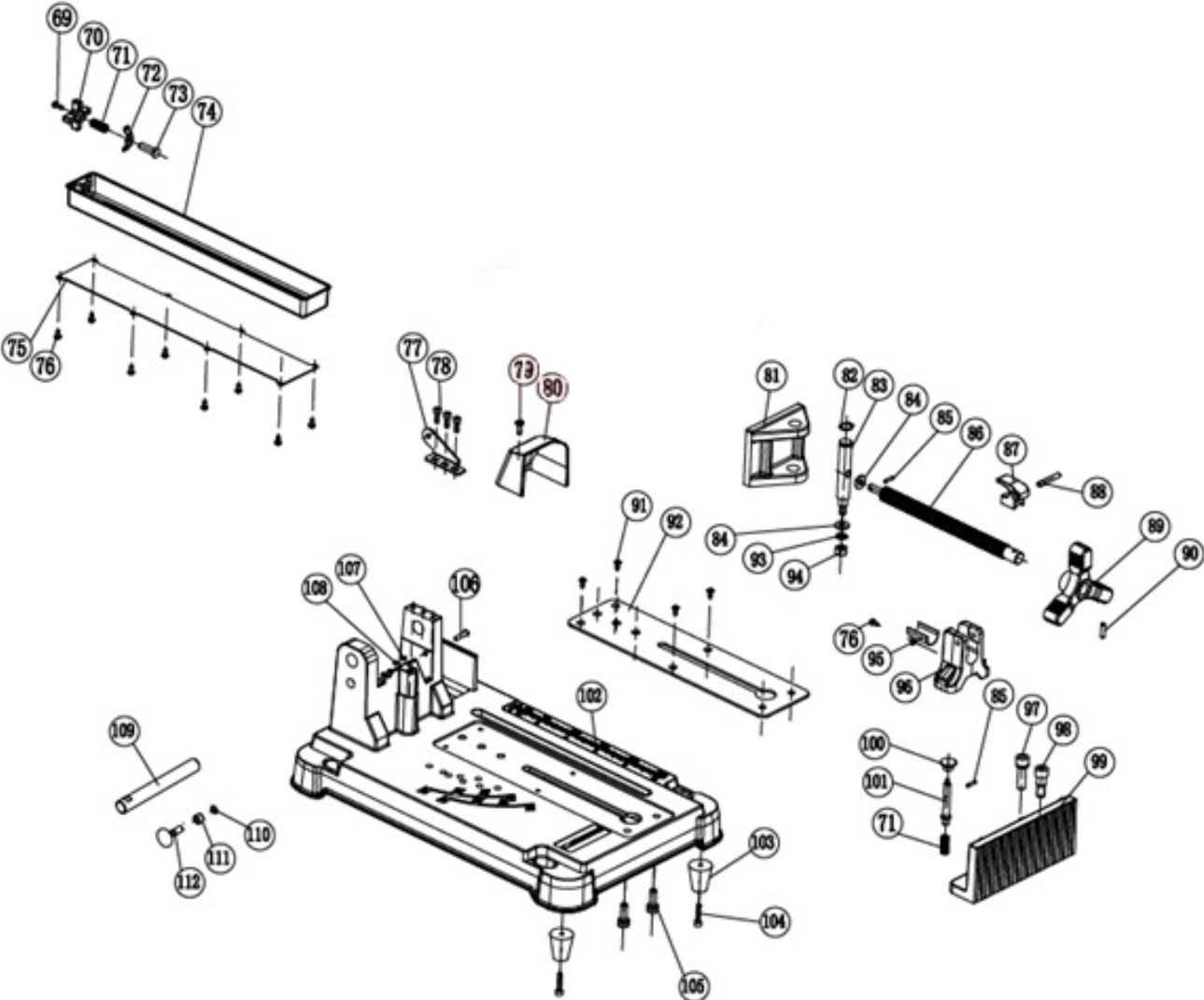

7.2 Spare parts list

No.	Code	Description	Status	Qty
1	EDC355.0001	Screw ST4x14mm	N/A	4
2	EDC355.0002	Back motor cover	N/A	1
3	EDC355.0003	Motor housing	N/A	1
4	EDC355.0004	Screw set M6x30	N/A	4
5	EDC355.0005	Carbon brush holder	N/A	2
6	EDC355.0006A	Carbon brush set 220/230V		2
	EDC355.0006B	Carbon brush set 110/120V		
7	EDC355.0007	Carbon brush cover		2
8	EDC355.0008A	Field 220/230V		1
	EDC355.0008B	Field 110/120V		
9	EDC355.0009	Screw ST5x80mm	N/A	2
10	EDC355.0010	Air deflector	N/A	1
11	EDC355.0011	Deflector cap	N/A	1
12	EDC355.0012	Bearing 6000	N/A	3
13	EDC355.0013A	Armature 220/230V		1
	EDC355.0013B	Armature 110/120V		
14	EDC355.0014	Bearing 6202	N/A	1
15	EDC355.0015	Screw ST4x16mm	N/A	12
16	EDC355.0016	Right handle	N/A	1
17	EDC355.0017	Cable guard	N/A	1
18	EDC355.0018EU	Plug EU 220/230V	N/A	1
	EDC355.0018USA	Plug USA 110/120V		
	EDC355.0018UK/GCC	Plug UK / GCC 220/230V		
	EDC355.0018UK	Plug UK 110V 16A		
19	EDC355.0019	Cutting arm	N/A	1
20	EDC355.0020	Top handle	N/A	1
21	EDC355.0021	Screw set M5x20mm	N/A	4
22	EDC355.0022	Left handle	N/A	1
23	EDC355.0023	Cable grip	N/A	1
24	EDC355.0024	On- / off- switch		1
25	EDC355.0025	Inductance	N/A	1
26	EDC355.0026	Capacitance	N/A	1
27	EDC355.0027	Bottom handle	N/A	1
28	EDC355.0028	Spindle lock spring	N/A	1
29	EDC355.0029	Spindle lock pin	N/A	1
30	EDC355.0030	Screw M6x20	N/A	4
31	EDC355.0031	Ø6 washer	N/A	4
32	EDC355.0032	Fixed guard	N/A	1
33	EDC355.0033	Plastic ring	N/A	1
34	EDC355.0034	Screw set M5x20mm	N/A	4
35	EDC355.0035	Spindle	N/A	1
36	EDC355.0036	Front motor cover	N/A	1

No.	Code	Description	Status	Qty
37	EDC355.0037	Gear shaft	N/A	1
38	EDC355.0038	Bolt 5x10mm	N/A	1
39	EDC355.0039	Middle gear	N/A	1
40	EDC355.0040	Bearing 609	N/A	1
41	EDC355.0041	Big gear	N/A	1
42	EDC355.0042	Bearing 6203	N/A	1
43	EDC355.0043	Cross screw 4x10mm	N/A	2
44	EDC355.0044	Spring washer M4	N/A	2
45	EDC355.0045	Connection bracket	N/A	1
46	EDC355.0046	Nut M4	N/A	2
47	EDC355.0047	Nut M5	N/A	2
48	EDC355.0048	Nut M6	N/A	2
49	EDC355.0049	Connecting rod	N/A	1
50	EDC355.0050	Retractable blade cover	N/A	1
51	EDC355.0051	Retractable blade cover washer	N/A	1
52	EDC355.0052	Spindle deflector	N/A	1
53	EDC355.0053	Blade flange		1
54	130.355/80	Saw blade 355mm 80T (standard)		1
	130.355/66	Saw blade 355mm 66T (stainless steel)		
55	EDC355.0055	Hand protection shield	N/A	1
56	EDC355.0056	Screw M5x12mm	N/A	2
57	EDC355.0057	Spring washer Ø5	N/A	2
58	EDC355.0058	Bolt M6x8mm	N/A	2
59	EDC355.0059	Spindle cover	N/A	1
60	EDC355.0060	Spindle bolt M10x20mm		1
61	EDC355.0061	Small flange		1
62	EDC355.0053	Blade flange		1
63	EDC355.0063	Spring for retractable blade cover		1
64	EDC355.0064	Cross screw M6	N/A	2
65	EDC355.0065	Soft start module		1
66	EDC355.0066	Hexagon bolt M8x45	N/A	1
67	EDC355.0067	Hexagon nut M8	N/A	1
68	EDC355.0068	Spring for cutting arm	N/A	1
69	EDC355.0069	Screw M4x12	N/A	1
70	EDC355.0070	Knob	N/A	1
71	EDC355.0071	Compression spring		2
72	EDC355.0072	Locating piece	N/A	1
73	EDC355.0073	Fixed screw	N/A	1
74	EDC355.0074	Dust box	N/A	1
75	EDC355.0075	Dust box plate	N/A	1
76	EDC355.0076	Screw M4x8	N/A	9
77	EDC355.0077	Connection plate	N/A	1
78	EDC355.0078	Hexagon screw M5x15	N/A	3
79	EDC355.0079	Screw M5x15	N/A	2

No.	Code	Description	Status	Qty
80	EDC355.0080	Dust guard	N/A	1
81	EDC355.0081	Clamp	N/A	1
82	EDC355.0082	Circlip 15	N/A	1
83	EDC355.0083	Pin	N/A	1
84	EDC355.0084	Washer	N/A	2
85	EDC355.0085	Spring pin 3.5x16	N/A	2
86	EDC355.0086	Pressure rod	N/A	1
87	EDC355.0087	Quick lock and release lever	N/A	1
88	EDC355.0088	Shaft	N/A	1
89	EDC355.0089	Clamp knob	N/A	1
90	EDC355.0090	Spring pin 4.5x20	N/A	1
91	EDC355.0091	Cross screw M4x0.7	N/A	4
92	EDC355.0092	Reinforced plate	N/A	1
93	EDC355.0093	Spring washer	N/A	1
94	EDC355.0094	Nut M8	N/A	1
95	EDC355.0095	Support plate	N/A	1
96	EDC355.0096	Fixed support	N/A	1
97	EDC355.0097	Angle lock screw		1
98	EDC355.0098	Hexagon screw M10x30		1
99	EDC355.0099	Plate	N/A	1
100	EDC355.0100	Positioning knob		1
101	EDC355.0101	Angle lock pin		1
102	EDC355.0102	Aluminium base	N/A	1
103	EDC355.0103	Rubber foot	N/A	2
104	EDC355.0104	Hexagon screw M5x25	N/A	2
105	EDC355.0105	Cross screw set M8x25	N/A	2
106	EDC355.0106	Cross screw M6x30	N/A	1
107	EDC355.0107	Nut M6	N/A	1
108	EDC355.0108	Locked nut M6	N/A	1
109	EDC355.0109	Fixed pin	N/A	1
110	EDC355.0110	O-ring 7.5x1	N/A	1
111	EDC355.0111	Steel bushing 8x12x8	N/A	1
112	EDC355.0112	Arm lock pin		1

8. Warranty and service

Warranty

EUROBOOR B.V. warrants this machine to be free of material defects and workmanship errors under normal use for a period of 12 months after date of purchase. This 12 month period can be extended to 24 months in total by registering the product on our website:

<https://Euroboor.com/support/register/>

Serial number:

Date of purchase:

Service

To maximise the lifetime of your EUROBOOR machine always use service and parts from an official EUROBOOR distribution channel. Whenever in need of such, always contact original point of sales or if no longer existent the distributor of EUROBOOR products in your country.

9. Certifications



9.1 CE declaration of conformity

EUROBOOR BV declares that the following appliance complies with the appropriate basic safety and health requirements of the EC guidelines based on its design and type, as brought into circulation by EUROBOOR BV.

<i>Designation/function</i>	Dry cut-off metal sawing machine
<i>Brand</i>	EUROBOOR
<i>Types</i>	EDC.355
<i>Ratings and principal</i>	230 - 240V AC, 50-60Hz, Class II
<i>Characteristics</i>	Power 2,480 W (11A) Speed 1,450 rpm
<i>Applicable guidelines</i>	2006/42/EC: The Machinery Directive
<i>Used standards</i>	EN 62841-1:2015+AC:15 EN 62841-3-10:2015+A11:17
Testing laboratory	Intertek

Zoetermeer, 7 April 2022

Albert Koster

Managing Director

9.2 Intertek proof of certification

Report No.: SH12110495-001

Certified product: Cutting off grinder

Model: EDC.355

Fulfilled standard(s) Stationary and Fixed Electric Tools UL987: Seventh Ed., Rev. June 4, 2010;
Bench Tools CAN/CSA-C22.2 No.71.2-08 August 1, 2010

The standard(s) listed here reflect the status at the time of release of this certificate.

Date of issue: 15-1-2013

Certificate type: Intertek authorization mark

This authorizes the application of the Certification Mark(s) shown below to the models described in the Product(s) covered section when made in accordance with the conditions set forth in the Certification Agreement and Listing report. This authorization also applies to multiple listee model(s) identified on the correlation page of the Listing report.

