

User manual
V 2.0 EN
Framenumbers:
3601901xxx

 **EUROBOOR**
FOR PROFESSIONALS BY PROFESSIONALS

Cordless magnetic drilling machine

EBM.360

Serial number:

Date of purchase:

Don't forget to register your machine at:

www.euroboor.com/register

[only when registered you benefit from extended warranty]

Congratulations on purchasing this premium magnetic drilling machine. At Euroboor we strive to exceed our customers' expectations by developing and providing premium and innovative portable drilling and cutting solutions. We believe that a professional like you must be able to rely on a professional supplier. Which has led us to become a major player in the industrial world, with our own factory and several offices worldwide. All because we have always listened to our customers and to the demands from the market.

Our vision is focused on developing innovative portable tools that add value for our customers and facilitate them in their daily work. We never lose sight of sustainability, time savings and cost savings.

Enjoy your new machine!

Before operating your new magnetic drilling machine, please first read all instructions. You find the instructions in this manual and on the warning label on your machine. With proper use, care and maintenance your machine will provide you with years of premium drilling performance.

TO REDUCE THE RISK OF INJURY USER MUST READ AND UNDERSTAND ALL INSTRUCTIONS

To view all our offices and their contact information please visit:

www.euroboor.com

Table of contents

Inhoudsopgave

1. Safety	4
1.1. General safety instructions.....	4
1.2. Specific safety information.....	7
2. Description	8
2.1. Intended use.....	8
2.2. Description and features.....	8
2.3. Box contents.....	9
2.4. Serial number.....	9
2.5. Technical data.....	1
2.6. Symbols.....	11
2.7. Environmental.....	12
3. Preparation & adjustment	13
3.1. Assembly.....	13
3.2. Prior to use.....	15
4. Description	16
4.1. Control panel.....	16
4.2. Spindle.....	17
4.3. Electromagnet.....	17
4.4. Switching motor on and off.....	18
4.5. Tool lubrication.....	19
4.6. Safety rules 37V/2.6Ah lithium -ion battery pack.....	19
4.7. Battery charger.....	23
5. Working with operation tools	24
5.1. Annular cutters.....	24
5.2. Twist drills.....	26
5.3. Countersinks.....	26
6. Maintenance	27
7. Trouble shooting	29
8. Exploded view & spare part list	31
8.1. Exploded views.....	31
8.2. Spare part lists.....	32
8.3. Wiring diagram.....	33

1. Safety

1.1 General safety instructions

Do not use this magnetic drilling machine before you have thoroughly read and completely understood this manual, specifically the “General safety instructions” and “Specific safety information” , including the figures, specifications, safety regulations and the signs indicating DANGER, WARNING and CAUTION.



WARNING: When using power tools basic safety precautions should always be followed to reduce the risk of fire, shock and personal injury.

Please also observe the relevant national industrial safety regulations. Non-observance of the safety instructions can lead to a shock, burns and/or severe injuries.

This manual should be kept for later use and enclosed with the magnetic drilling machine, should it be passed on or sold.

Work area

1. Keep your work area clean and well lit. Cluttered and dark work areas increase the chance of accidents.
2. Do not operate a magnetic drilling machine in explosive atmospheres, such as in the presence of flammable liquids, gases or dust. A magnetic drilling machine may create sparks which could ignite the dust or fumes.
3. Keep bystanders, children and visitors away while operating a magnetic drilling machine. Distractions can cause you to lose control.

Personal safety

1. Stay alert, watch what you are doing and use common sense when using a magnetic drilling machine. Do not use the machine while tired or under the influence of drugs, alcohol, or medication. A moment of inattention while operating a magnetic drilling machine may result in serious personal injury.
2. Dress properly. Do not wear loose clothing or jewelry. Keep your hair, clothing and gloves away from moving parts. Loose clothes, jewelry or long hair can be caught in moving parts.
3. Never place hands, fingers, gloves or clothing near drilling area or rotating machine parts.
4. Remove adjusting keys or switches before turning the machine on. A wrench or a key that is left attached to a rotating part of the machine may result in personal injury.
5. Do not overreach. Keep proper footing and balance at all times. Proper footing and balance enables better control of the magnetic drilling machine in unexpected situations.
6. Use safety equipment. Always wear eye protection. Dust mask, non-skid safety shoes, hard hat and hearing protection must be used for optimal safety.
7. Always use supplied safety chain during any work on non-horizontal surfaces. Magnetic drilling machine can release from surface.

When using this machine, you MUST wear ear and eye protection.

Machine use and care

1. When using the machine on non-horizontal surfaces, you must use cutting paste. Do not use oil because the oil can drip into the motor unit.
2. While operating the machine, the annular cutter must be cooled and lubricated with high quality cutting lubricants.
3. Always remove the slug from the annular cutter after each hole. **Caution**; the slug may be hot!
4. Use clamps or other practical solutions to secure and support the workpiece to a stable platform. Holding the workpiece by hand or against your body is unstable and may lead to loss of control.
5. Do not use the machine when the switch does not turn it on or off. Any machine that cannot be controlled with the switch is dangerous and must be repaired.
6. Store your magnetic drilling machine out of reach for children and other untrained persons. Tools are dangerous in the hands of untrained users.
7. Maintain your machine with care. Keep cutting tools sharp and clean. Properly maintained tools, with sharp cutting edges are less likely to break and are easier to control.
8. Check for misalignment of moving parts, breakage of parts and any other condition that may affect the machine's operation. If you detect damaged have the machine serviced before use. Many accidents are caused by poorly maintained tools.
9. Only use accessories that are recommended by Euroboor for your machine model. Accessories that are suitable for one machine may become hazardous when used on another machine.

Service

1. Tool service must be performed only by qualified repair personnel. Service or maintenance performed by unqualified personnel could result in risk of injury.
2. When servicing a tool, use only identical replacement parts. Follow instructions in the maintenance section of this manual. Use of unauthorized parts or failure to follow maintenance instructions may create an injury.
3. Euroboor offers Armature kits containing official Euroboor spare parts suitable for your magnetic drilling machine.

1.2 Specific safety information

- Keep your fingers away from the drilling area;
- Avoid touching the slug that is automatically ejected by the pilot pin when the working procedure is finished. Contact with the slug when it is hot, or if it falls, can cause personal injuries;
- Always use the safety guard. Before switching on the machine ensure that the guard is closed securely;
- Always use the safety strap;
- The magnetic drilling machine is suitable for use on steel with a thickness starting from 6 mm, with zero air gap between the magnet core surface and the mounting surface. Curvature, coats of paint and surface irregularities will create an air gap. Keep the air gap to a minimum;
- Always place the machine on a flat surface;
- Do not clamp the magnetic drilling machine on small or irregular shaped objects;
- Always place the machine on a surface that is clear of shavings, chips, swarf and surface dirt;
- Keep the magnet clean and free of debris and swarf;
- Do not switch on the machine before checking whether the magnetic stand has been tightened firmly to the mounting surface;
- Adjust the machine so cutter does not extend into the workpiece before drilling. Do not perform any design, assembly or construction activities on the workpiece while the machine is switched on;
- Before switching on the machine, make sure all accessories have been mounted correctly;
- Do not switch on the machine until it has been mounted and installed according to all above mentioned instructions;
- Always use the recommended speed for the accessories and material you are working with;
- Do not use the machine on the same workpiece on which electric welders are working;
- Only use an appropriate cutting lubricant. Euroboor offers a wide range of well-considered cooling and lubrication products to match your requirements;
- Do not use liquid cutting fluids while drilling vertically or overhead. Dip the cutter in cutting paste or apply an appropriate spray for these applications;
- Do not pour cutting fluid into the reservoir while it is mounted in the bracket. Do not allow cutting fluid to enter the drill motor;
- Before use, ensure movable safety guard operates properly;
- In case of a jammed cutter, turn off the machine and then remove the reason for the jam before turning on the machine again.

Residual risk

In spite of following the relevant safety regulations and their implementation, certain residual risks cannot be avoided.

These are:

- Impairment of hearing
- Risk of personal injury from flying particles
- Risk of burns due to accessories becoming hot during operation
- Risk of personal injury due to prolonged use.

Always try to reduce these risks as much as possible.

2. Description

2.1 Intended use

This magnetic drilling machine is intended for commercial use as a drilling machine for drilling materials with a magnetizable surface using annular cutters and twist drills, and for countersinking in a weather-protected environment using the application tools and accessories recommended by Euroboor.

The magnetic drilling machine can be used horizontally, vertically or overhead.

2.2 Description and features



[image 1-1]

2.3 Case content

- 1 x EBM.360 Magnetic drilling machine
- 1 x battery pack 37 V / 2.6 Ah
- 1 x battery charger
- 1 x safety guard
- 3 x handles
- 1 x hex key 2.5 mm
- 1 x hex key 4 mm
- 1 x hex key 5 mm
- 1 x lubrication system
- 1 x safety chain
- 1 x bottle (200 ml) of IBO.10 cutting oil
- 1 x user manual
- 1 x safety ear protection
- 1 x safety goggles
- 1 x safety gloves

2.4 Serial number

The serial number is mentioned on the machine three times: engraved on the frame, engraved on the magnet and on the serial no. sticker on the motor housing. Additional serial no. stickers are provided with the machine for your administration.

The serial number will help you, your dealer and Euroboor to validate and identify the machine.

For example:

0301909001

breaks down to:

030 19 09 001

Machine series

Year of manufacture







Month of manufacture

Identification number

2.5 Technical data

	Metric	Imperial
Annular cutting	Ø 12 - 36 mm	Ø 7/16" – 1 7/16"
Twist drilling	Ø 1 - 13 mm	Ø 1/16" – 1/2"
Threading	-	-
Countersinking	Ø 10 – 40 mm	Ø 3/8" – 1 9/16"
Length	297 mm	11 11/16"
Width	112 mm	4 7/16"
Height	420 - 610 mm	16 9/16" – 24"
Stroke	230 mm	9 1/16"
Weight	15 kg	33 lbs
Magnet (l x w x h)	160 x 80 x 42 mm	6 5/16" x 3 1/8" x 1 5/8"
Magnetic force	1700 kg	3745 lbs
Battery	37 V / 2,6 Ah Li-ion	37 V / 2,6 Ah Li-ion
Charging time	0% to 75% - 17 minutes 75% to 100% - 58 minutes Fully charged - 75 minutes	
Speed (no load)	506 rpm	506 rpm
Speed (load 1300 W)	375 rpm	375 rpm
Spindle (Weldon)	19,05 mm	3/4"

2.6 Symbols

Symbol	Term, meaning	Explanation
	Read documentation	Be absolutely sure to read the documentation in this user manual and specifically the “General safety instructions” and “Specific safety information”.
	Wear ear protection	Use ear protection during operation.
	Wear eye protection	Use eye protection during operation.
	Danger/warning/caution	Read and apply the information in the adjacent text!
	European conformity symbol	Confirms the conformity of the magnetic drilling machine with the directives of the European Community.
	Class of protection I	Product with basic insulation and exposed (touchable) conductive parts additionally connected to the protective earth conductor.
mm	Millimeter	Unit of measurement for length, width, height or depth.
kg	Kilogram	Unit of measurement for the mass.
V	Volt	Unit of measurement for the electric voltage.
A	Ampere	Unit of measurement for the electric current intensity.
W	Watt	Unit of measurement for the output.
rpm	Revolutions per minute	Unit of measurement for the revolutions.
no	No load speed	Revolution speed at no load.

2.7 Environmental



Separate collection. This product must not be disposed of with normal household waste.



Separate collection of used products and packaging allows materials to be recycled and used again. Re-use of recycled materials helps prevent environmental pollution and reduces the demand for raw materials.

Local regulations may provide for separate collection of products from the household, at municipal waste sites or at the retailer when you purchase a new product.

3. Preparation & adjustment

3.1 Assembly



WARNING: To reduce the risk of injury, turn machine off before installing and removing accessories, before adjusting or changing set-ups or when making repairs. Be sure all switches are in the OFF position. An accidental start-up can cause injury.

Fitting the feed handles

1. Fit each of the three feed handles by screwing them into the hub in clockwise direction.
2. Tighten firmly by hand.

The handles are supposed to face slightly outward. Be careful not to cross-thread any of the components.

Battery pack

Charge the battery before use. If performance diminishes, recharge the battery pack. The ideal storage temperature is between 10° and 30°C.

Li-ion battery packs (37 V) have a capacity and signal display:

- Press button and the charge level is displayed by the LED lights;
- If red LED is displayed, the battery pack is almost flat and must be recharged;
- If all LED lights are flashing, the battery pack is too warm. Allow the battery pack to cool down.

Removing and inserting the battery pack

Removal

Press both buttons on the side of the battery pack and take out the battery from its position.

Inserting

Slide in the battery pack completely until it engages.

Removing and inserting an accessory



Remove the battery pack from the machine before any adjustments, conversions or servicing are performed.



If the tool is jammed: Press the RED switch "O" to switch off the motor unit. Then find out what is causing the machine to jam. Watch out : the annular cutter might be hot.

The tool holder accepts annular cutters with a 19,05 mm (3/4") Weldon shank with one or more flats.



WARNING: The teeth of a cutter are very sharp and can be dangerous.

1. In order to fit an accessory it is necessary to remove the guard;
2. Insert the shank of the accessory as far into the tool holder as possible;
3. Tighten the two allen screws with allen key;
4. To remove the accessory, loosen the allen screws and take out the accessory.

Mounting the safety guard

The safety guard protects against chippings and accidental contact and must always be mounted before operation.

1. Hold the guard in front of the magnet, align the slots in the guard with the holes in the magnet.
2. Fit the screws into the holes located in the side of the magnet.



WARNING: Always use the safety guard.

Fitting the lubrication system

The lubrication system can only be used for horizontal drilling (the drill being used vertically).

1. Hang the coolant tank on the coolant tank holder.
2. Position and tighten the attachment pin.
3. Connect the coolant hose to the fitting on the gearbox. Make sure the hose is connected fully and tightly.
4. To disconnect the coolant hose, press the blue ring on the connection and gently pull out the hose.

In order to use the lubrication system, it must be filled with a sufficient amount of cutting fluid.

1. Make sure the flow regulator is closed;
2. Unscrew the cap;
3. Fill the container with cutting fluid;
4. Screw the cap back on.



WARNING: Do not use the lubrication system in vertical or overhead drilling applications. Instead use Euroboor cutting paste.

Fitting the safety chain

1. Pass the safety chain through the frame grip opening.
2. Wrap the chain around the workpiece.
3. Securely close the chain using the lock.



WARNING: Always use the safety chain when drilling vertically and/or up-side-down. The safety chain does not replace the magnetic force of the magnetic drilling machine: it is simply used to secure against falling in the event of a magnet malfunction.

3.2 Prior to use

Please make sure that the contacting surface for the magnet is level, clean and rust free. Remove any varnish or primer. When working on materials that are not magnetizable, suitable fixation devices, obtainable as accessories from Euroboor, e. g. suction plate, vacuum plate or pipe-drilling machine must be used.

When working on steel materials with a material thickness of less than 6 mm, the workpiece must be reinforced with an additional steel plate in order to guarantee the magnetic holding power.

Check the machine for possible damage; Before using the machine, you must carefully check the protective components or slightly damaged components to ensure they are operating perfectly and as intended.

Check that moving parts are in perfect working order, do not jam and check whether the parts are damaged. All parts must be correctly installed and fulfill all conditions necessary to ensure perfect operation of the machine.

Damaged protective components must be repaired or replaced according to specifications by Euroboor or any authorized Euroboor dealer.

DO NOT use under wet conditions or in presence of flammable liquids or gases.

DO NOT let children come into contact with the machine. Supervision is required when inexperienced operators use this machine.

Useful tips

- Try a few simple projects using scrap material until you develop a “feel” for the magnetic drilling machine.

- Let the machine run in for a period of eight to ten hours before starting with big operations. Do not load the machine too much during this run-in period.
- Never use the machine with serious overload.
- Keep the machine clear from moisture at all times to protect the machine, yourself and others.

4. Using the machine



WARNING: Always observe the safety instructions and applicable regulations.



WARNING: To reduce the risk of serious personal injury, turn the machine off before making any adjustments or removing/installing attachments or accessories.

4.1 Control panel

The control panel

The control panel on your magnetic drilling machine is designed for maximum ease of use and safety.

1 - The ON Switch (GREEN):

This (upper) switch is used to switch the motor unit On ("I");

2 – The OFF Switch (RED)

This (lower) switch is used to switch the motor unit Off ("O");

3 - The Magnet Switch (WHITE):

This switch is used to turn on the main power and also to switch the magnet On and Off. This switch also indicates if the generated magnetic force is enough for the tool to operate safely.

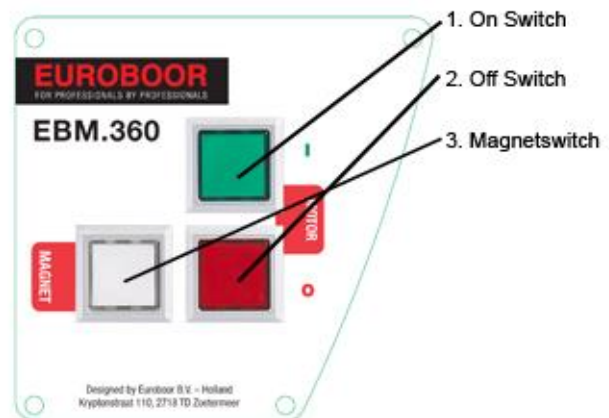

[image 2-2]

The indicator is enclosed in the magnet switch and has two colors:

- GREEN – SAFE for use
- Alternately lighting up RED and GREEN and making a beeping sound – Not safe for use

In order to operate properly, the machine has to be turned on following the procedure as described below.

Activating the magnet

Connect the machine to the work piece. To activate the magnet, press the WHITE switch (image. 2-2). The switch will be lit GREEN if the generated magnetic force is sufficient to work safely. If the switch starts flashing RED and GREEN and making a beeping noise, there is not enough magnetic force and the motor is not able to start.

To deactivate the magnet, press the same button again.

Turning the motor on and off

The motor can only be switched on when the magnet is activated. To turn ON the motor, press the GREEN button "I", the WHITE magnet switch will be lit yellow. To turn OFF the motor, press the RED button "O".

4.2 Spindle

This machine is equipped with a detachable spindle drive with 19,05 mm (3/4")Weldon connection. To accommodate a drill chuck, either directly to the gearbox output shaft or with an adapter, the spindle can be detached.

1. Hold the gearbox output shaft in place with a narrow 18 mm spanner;
2. Loosen the spindle from the gearbox output shaft in counterclockwise direction with a 22 mm spanner at the top of the spindle;
3. Gently pull the spindle through the coolant ring and spindle holder, while holding the coolant ring in place;
4. You are now able to attach an adapter, drill chuck or different accessory to the gearbox output shaft. The thread specification is 1/2" x 20 UNF.

To reattach the spindle, follow above steps in reverse order. Make sure all parts are correctly aligned and firmly tightened.

4.3 Electromagnet

Make sure the magnetic drilling machine is placed on a smooth, clean, level and solid surface without any objects or debris to guarantee maximum adhesion.

The workpiece must be at least 6 mm thick for the magnet to stick to drill safely. In case the workpiece is between 3 and 6 mm, make sure to make a proper base to create a good magnetic field.

The electromagnet will work best on surfaces of at least 10 mm thickness.

When the electromagnet is not able to create a good enough magnetic field, this may be caused by

- Surface not being flat
- Workpiece is not magnetizable (e.g. aluminum)
- Workpiece is coated or painted
- Workpiece is not thick enough

If the LED light of the Magnet Switch lights up GREEN, the magnet is generating sufficient attachment force. If this switch alternately lights up RED and GREEN together with a beeping sound, the magnet does not generate sufficient attachment force and the motor will not start (for safety reasons).

Make sure to solve any of these matters before proceeding in any way and creating unsafe situations.



CAUTION: *The Euroboor EBM.360 does not allow the motor to turn on if LED light in the Magnet Switch alternately lights up RED/GREEN. If turning on the machine is possible while this happens, please return the machine to Euroboor or any authorized dealer.*



WARNING: *Do not use this machine when LED indicator is RED. Magnet may not generate sufficient attachment force.*

We want to point out that above mentioned precautions and indicators do not guarantee that the magnet will not release from the material. Euroboor accepts no liability when it comes to the magnet indicator not functioning or functioning poorly.

Make sure that the magnet attaches tightly to the work piece before turning on the motor unit of the magnetic drilling machine. Euroboor magnets have two coils; make sure that both coils are in contact with the material.

Always use the safety chain included. Drilling above your head is extremely dangerous and is not recommended. For the use of magnetic drilling machines on pipes, not-flat or non-magnetic materials, we refer to our catalog or our website www.euroboor.com where several vacuum tightening systems, pipe clamping systems Tube machines can be found.

4.4 Switching motor on and off

The motor unit can only be switched ON when the magnet is activated. To switch the motor ON, press the green button with marking "I". To switch the motor OFF, press the red button with marking "O".

4.5 Tool lubrication

In horizontal applications

In order to use the lubrication system, the tank must be filled with a cutting lubricant.

1. Make sure the flow regulator is closed.
 2. Unscrew the cap.
 3. Fill the container with cutting lubricant.
 4. Screw the cap back on.
- Adjust the fluid flow as required using the flow regulator;
 - Add more cutting lubricant when the shavings (metal chips) become blue.

Vertical and overhead applications

Dip the cutter in cutting paste or apply an appropriate spray.



WARNING: Do not use the lubrication system in vertical or overhead drilling applications. Instead use Euroboor cutting paste

Make sure to use only suitable cutting lubricants. Euroboor offers a wide range of cutting lubricants for all tool and material combinations. Proper cooling will help you create better and faster results, and extend the lifetime of your tools.

4.6 Safety rules 37 V/ 2.6 Ah lithium -ion battery pack

Read all instructions. Failure to follow all instructions listed below may result in shock, fire and/or serious injury.

- Remove the battery pack from the machine before any adjustments, conversions or servicing are performed.
- Before fitting the battery pack, make sure that the machine is switched off.
- Do not open the battery pack.
- Do not place the battery pack on or near fires, heaters, other high temperature locations or apply heat to the battery.
- Do not pierce the battery with any sharp objects, strike the battery with a hammer, tools, or heavy objects, step on the battery pack or otherwise damage the outer casing.
- Do not subject the battery pack to strong impacts or shocks.
- Do not expose the battery to water or any other type of liquid, or allow the battery to get wet.
- Do not leave the battery in direct sunlight, and avoid storing spare battery packs inside cars in extremely hot weather. Doing so may cause the battery to generate heat, rupture or ignite.

Using the battery in this manner may also result in a loss of performance and a shortened life expectancy. When a battery becomes too hot, the built-in protection circuitry is activated, preventing the battery from charging further. Heating the battery can destroy the safety devices, and can cause additional heating, rupture or ignition of the battery cells.

- Never short-circuit, reverse polarity, disassemble, damage or heat the battery pack over 100°C (212°F).
- If an exposed lithium-ion battery does start a fire, it may burn even more violently if it comes into contact with water or even the moisture in the air. **Do not throw water on a burning lithium battery!** A class C fire extinguisher must be used.
- Do not use the battery pack if the battery pack casing is broken or if a battery pack emits an unusual odor, smoke, excessive heat or leaks any substance. Avoid contact with any substance leaking from the battery pack.
- Keep out of reach from children and pets. Exposure to battery pack voltage could result in death or serious injury.
- The cells within the battery pack contain toxic substances. Do not attempt to open battery packs. Do not insert any object into the battery packs or use any device to pry at the battery pack casing. If you insert an object into any of the battery packs' ports or openings you could suffer shock, injury, burns or cause a fire. Attempting to open the battery pack casing will damage the casing and could release toxic and harmful substances, and will render the pack unusable.
- If battery fluid leaks out and comes into contact with your skin, rinse immediately with plenty of water. If battery fluid leaks out and comes into contact with your eyes, wash them with clean water and seek medical attention immediately.
- As with all rechargeable batteries, do not charge near flammable materials.
- Do not disassemble or modify the battery pack. The battery contains safety and protection devices which, if damaged, may cause the battery to generate heat, rupture or ignite.
- Any modification may damage the battery pack or cells and will invalidate any warranty claim.
- If you happen to get any electrolyte from the cells on your skin, wash thoroughly with soap and water. If in your eyes, do not rub. Rinse thoroughly with water and seek medical attention immediately.



CAUTION: *If at any point during the charging process none of the LEDs are lit, remove the battery pack from the charger to avoid damaging the product. Do not insert another battery. Return the charger and battery to your nearest service center for service or replacement.*



CAUTION: *Charge in a well ventilated area. Do not block charger vents. Keep them clear to allow proper ventilation.*

Battery protection features

Euroboor 37 V / 2.6 Ah lithium-ion batteries are designed with features that protect the lithium-ion cells and maximize battery life. Under some operating conditions, these built-in features may cause the battery and magnetic drilling machine to act differently from nickel-cadmium batteries.

During some applications, the battery electronics may signal the battery to shut down and cause the tool to stop running. To reset the battery and tool, release the trigger and resume normal operation.

NOTE: To prevent further shut down of the battery, avoid forcing the tool. Switching to a lower speed will also prevent shut down.

If releasing the trigger does not reset the battery and tool, the battery pack is depleted. If depleted, the battery pack will begin charging when placed on the lithium-ion charger.

To charge

A fully discharged battery pack with a temperature between 0° (32°F) and 65° (150°F) will charge in about an hour.

- Use battery pack only with the recommended Euroboor charger.
- Connect the charger to a power supply. Make sure the power supply is normal household voltage, **220 volts, AC only, 60 Hz.**
- Attach the battery pack to the charger by aligning the raised ribs on the battery pack with the grooves in the charger, then slide the battery pack onto the charger.
- Do not place the charger and battery pack in an area of extreme heat or cold. They will work best at normal room temperature.

NOTE: The charger and battery pack should be placed in a location where the temperature is more than 10° (50°F) but less than 38° (100°F).

- The battery pack will become slightly warm to the touch while charging. This is normal and does not indicate a problem.
- After charging is complete, the green LED will remain on until the battery pack is removed from the charger or charger is disconnected from the power supply.
- When batteries become fully charged, unplug the charger from the power supply and remove the battery pack.

Charging a hot battery pack

If the battery pack is above normal temperature range, the red LED will begin flashing and the green LED will be off. When the battery pack cools down to approximately 150°F, the charger will automatically begin charging again.

Charging a cool battery pack

If the battery pack is below normal temperature range, the red LED will begin flashing and the green LED will be off. When the battery warms to a temperature of more than 32°F, the charger will automatically begin charging again.

Cold weather operation

The lithium-ion battery pack can be used in temperatures down to -4°F. Put the battery pack on the magnetic drilling machine and use the tool in a light duty application. After about a minute, the pack will have warmed up and begin operating normally.

Maintenance

This battery pack is equipped with lithium-ion rechargeable batteries. Length of service from each charging will depend on the type of work you are doing.

These batteries have been designed to last as long as possible. However, like all batteries, they will eventually wear out. Do not disassemble battery pack and attempt to replace the batteries. Handling of these batteries, especially when wearing rings and jewelry, could result in a serious burn.

To obtain the longest possible battery life from Euroboor lithium-ion batteries, we suggest the following:

- Remove the battery pack from the charger once it is fully charged and ready for use.

For battery pack storage longer than 30 days:

- Store the battery pack where the temperature is below 80°F and away from moisture.

- Store battery packs in a 30%-50% charged condition.
- Every six months of storage, charge the pack as normal.

Battery pack removal and preparation for recycling

To preserve natural resources, please recycle or dispose of batteries properly.

This product contains lithium-ion batteries. Local, state or federal laws may prohibit disposal of lithium-ion batteries in ordinary trash.

Consult your local waste authority for information regarding available recycling and/or disposal options.

**WARNING:**

Upon removal, cover the battery pack's terminals with heavy-duty adhesive tape. Do not attempt to destroy or disassemble battery pack or remove any of its components. Lithium-ion batteries must be recycled or disposed of properly. Also, never touch both terminals with metal objects and/or body parts as short circuit may result. Keep away from children. Failure to comply with these warnings could result in fire and/or serious injury.

4.7 Battery charger

Charging the battery

On the battery charger there are two lights; RED and GREEN.

When the RED light flashes the battery is charged between 2% - 80%. When the GREEN light flashes the last 20% of the battery is charged.

When the green light stops flashing and remains lit green, the battery is fully charged and ready for use.



CAUTION: When both the RED and GREEN light are simultaneously lit than either the battery charger or the battery itself is too hot. If the RED and GREEN light on the charger are alternately flashing RED/GREEN, there is a general error.

Battery charging temperature protection

If the battery reaches 50°C, the charger will stop charging. Error signals: the RED and GREEN light are simultaneously lit RED and GREEN. The charger will start charging again if the temperature of the battery is 45°C or less.

Signals on the machine

Signals well-functioning magnetic drilling machine

- When the EBM.360 magnetic drilling machine is well positioned on the work piece, press the magnet (white) switch to turn on the magnet. The LED will flash GREEN two times and then remain GREEN.
- When the motor is switched on (green switch), the magnet switch will be lit yellow.

Signaling malfunctioning of the magnetic drilling machine

- When the (white) magnet switch is flashing alternately RED/GREEN together with an acoustic sound, then there is not enough magnetic force or the magnet is not working.
- When the (white) magnet switch is flashing RED, the battery is low.
- When the (white) magnet switch is flashing YELLOW, there is over current and the motor will stop.

5. Working with drilling accessories

5.1 Annular cutters

Annular cutters only cut material at the periphery of the hole, rather than converting the entire hole to shavings. As a result, the energy required to make a hole is lower than for a twist drill. When drilling with an annular cutter, it is not necessary to drill a pilot hole.



WARNING: Do not touch the cutter or the parts close to the cutter immediately after operation, as they may be extremely hot and cause burns to the skin. Ensure nobody is in the work area where the metal core (slug) is ejected.

Drilling conditions

The ease with which material can be drilled depends on several factors including tensile strength and abrasion resistance. Whilst hardness and/or strength is the usual criterion, wide variations in machinability can exist among material showing similar physical properties.

The drilling conditions are dependent on requirements for tool life and surface finish. These conditions are further restricted by the rigidity of the tool and the workpiece, lubrication and machine power available. The harder the material, the lower the cutting speed.

Some materials of low hardness contain abrasive substances leading to rapid cutting edge wear at high speeds. Feed rates are governed by rigidity of set-up, volume of material to be removed, surface finish and available machine power.

Drilling a hole

Now that you have read the information and safety recommendations above, you are ready to actually start drilling. Follow these 12 steps for best drilling result :

1. Install the annular cutter.
 - Place the pilot pin into the cutter;
 - Align the flat faces on the cutter shank with the screws in the tool holder;
 - Make sure the cutter shank is entered fully and correctly;
 - Tighten the screws;

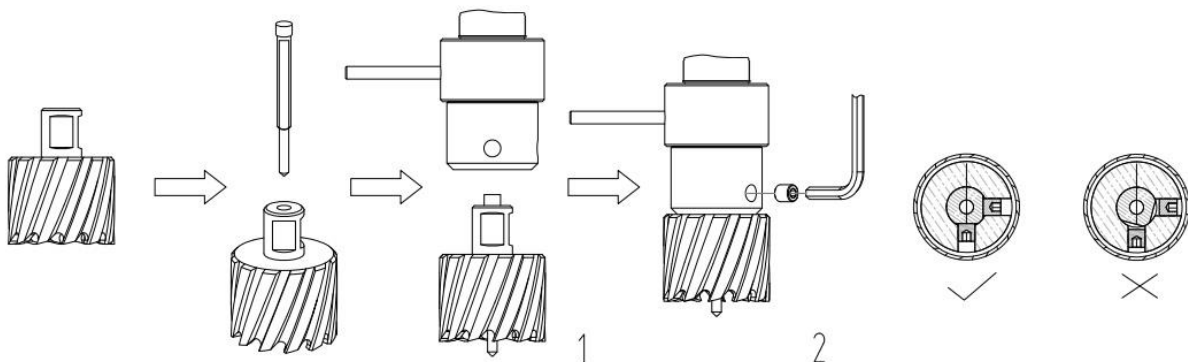

[image 3-1]

2. Precisely mark the centre of the hole.
3. Use the pilot pin to position the machine in the correct position, with the tip of the pilot pin to meet the marked center of the hole.
4. Switch on the magnet and verify that the drill is in the right position and that the machine is pushed tight against the work piece.
5. Fill the holes of the spindle with oil.
6. Switch the motor on and allow it to run at the required speed.
7. Turn the feed handles to start drilling. Apply only a slight pressure when the annular cutter touches the metal. Do not push the annular cutter with force into the metal.
8. Apply a regular pressure while drilling. The drilling performance does not improve by putting more pressure on the machine. Too much pressure will overload the motor and your annular cutter will be worn sooner.
A continuous, non-discoloured iron swarf is a sign of correct drilling speed and a well-cooled, sharp cutter. Let the cutter do the job and give it time to cut the metal!
9. Stop drilling regularly, refill the holes of the spindle and continue drilling.
10. Apply less pressure when the drill cuts through the material. The slug will be pushed out of the cutter by the pilot pin.
11. Turn the feed handles to put the motor in highest position and switch off the motor unit.
12. Remove the burrs, metal chips and clean the cutter and surface without getting injuries.

Caution: The metal slug can be sharp and very hot!

5.2 Twist drills

1. Remove the spindle as described in chapter Spindle (4.2);
2. Attach a drill chuck to the gearbox output shaft either directly or with an (extension) adapter;
3. Precisely mark the center of the hole, use the tip of the twist drill to position the machine correctly, with the tip of the twist drill to meet the marked center of the hole.

Steps 4-12: see chapter Annular cutters (5.1).

5.3 Countersinks

Thanks to its wide range of operating speeds, the machine can also be used for reaming or countersinking.

Follow the steps mention in chapter Twist drills.

6. Maintenance

Your Euroboor magnetic drilling machine has been designed to operate over a long period of time. Continuous satisfactory operation depends upon proper tool care and regular cleaning.



CAUTION: To reduce the risk of injury, turn the machine off before installing and removing accessories, before adjusting or changing set-ups or when making repairs. Be sure the switch is in the OFF position. An accidental start-up can cause injury.

Just as every magnetic drilling machine with moving parts, your Euroboor magnetic drilling machine also needs regular maintenance service. A few recommendations follow :

Visually check the machine for damage

The machine must be checked before operating for any signs of damage that will affect the operation of the machine. If the machine appears to be damaged it should not be used. Failure to do so may cause injury or death.

Cleaning

- Clean all dirt, dust, metal chips and burrs of your magnetic drilling machine;
- Blow dirt and dust out of the main housing with dry air as often as dirt is seen collecting in and around the air vents. Wear approved eye protection and an approved dust mask;
- Never use solvents or other harsh chemicals for cleaning the non-metallic parts of the tool. These chemicals may weaken the materials used in these parts. Use a cloth dampened only with water and mild soap. Never let any liquid get inside the tool; never immerse any part of the tool into a liquid.

Operation of the machine

The machines operation must be checked to ensure that all components are working correctly. Replace any defective parts immediately. This prevents properly functioning parts from being damaged.

Carbon brushes

Brushes should be checked to make sure there is no abnormal wear present. This should be checked at least once a week if used frequently. If the carbon brush has worn more than 2/3 the original length the brushes should be changed. Failure to do so may cause damage to the machine.

Check magnetic base

Before every operation the magnetic base should be checked to make sure that the base is flat and there is no damage present. An uneven magnet base will cause the magnet to hold not as efficiently and may cause injury to the operator.

When the machine is put out of use for a longer period, apply a small amount of machine oil to the underside of the magnetic base for rust protection. Clean the magnetic base again with next use.

Check machines grease

The gearbox grease should be checked once a month to ensure all moving components are covered to prevent wear. The grease should be changed at least once a year to ensure you gain the best from the machine.

Check armature

This should be checked at least once a month to check if there are visual signs of damage to the body or to the commutator. Some signs of wear will be seen on the commutator over a period of time this is normal as this is the part that comes in contact with the brushes but any signs of abnormal damage means the part should be replaced.

Adjustment of slide

An essential requirement of the machine is that the slide can move in a smooth and controlled manner, free of lateral movement and vibration.

This situation can be maintained by periodic adjustment of the slide and can be accomplished in the following manner:

1. Place the machine in an upright position and, by means of the capstan, raise the slide to its highest position. Clean the aluminum rails and apply a small amount of light machine oil to the wear surfaces;
2. Gently feed in setting screw with supplied Allen key 2.5 until slight resistance is encountered. Follow your way down adjusting all setting nuts and screws;
3. Operate the slide up and down a few times to test the movement and make any further necessary adjustments. Try to ensure that all the screws are exerting a uniform pressure on the slide from top to bottom. A perfectly adjusted slide will operate freely up and down without any sideways movement.

Lubricating the feed travel

The feed travel should be lubricated periodically with grease to ensure smooth operation.

- Raise the motor unit to the highest position possible;
- Lubricate the dove-tail guideway at both sides;
- Lubricate the gear rack.

After repeated use, the gear rack may become loose. If necessary, adjust the five self-locking set screws at the left side. Tighten screws in series until the gear rack moves freely in the dove-tail guideway but does not allow the motor to wobble.

Repair, modification and inspection

Repair, modification and inspection of Euroboor Magnetic drilling machines must be done by Euroboor or an Euroboor authorized dealer. The spare parts list will be helpful if presented with the machine to the Euroboor dealer for service when requesting repair or other maintenance.

Euroboor machines are constantly being improved and modified to incorporate the latest technological advancements. Accordingly, some parts (i.e. part numbers and/or design) may be changed without prior notice. Also, due to Euroboor's continuing program of research and development, the specifications of machines are subject to change without prior notice.



WARNING: *Since accessories, other than those offered by Euroboor, have not been tested with this machine, use of such accessories with this tool could be hazardous. To reduce the risk of injury, only Euroboor recommended accessories should be used with this machine.*

Consult your dealer for further information on the appropriate accessories.

7. Trouble shooting

Magnet and motor do not function	<ul style="list-style-type: none"> - The magnet switch is not connected to the power supply - Damaged or defective wiring - Defective fuse - Defective magnet switch - Defective control unit - Defective power supply
Magnet does function, the motor does not work	<ul style="list-style-type: none"> - Damaged or defective wiring - Carbon brushes are stuck or worn out - Defective magnet switch - Defective On / Off switch - Defective control unit - Defective armature and/or field
Magnet does not function, the motor does	<ul style="list-style-type: none"> - Defective magnet - Defective wiring of magnet - Defective control unit
Annular cutters break quickly, holes are bigger than the annular cutter	<ul style="list-style-type: none"> - Clearance in the guide - Bent spindle - Shaft extending from the motor is bent - Bent pilot pin
Motor running roughly and/or seizing up	<ul style="list-style-type: none"> - Bent spindle - Shaft extending from the motor is bent - Triangular guide not mounted straight - Dirt between spindle and triangular guide
Motor starts running when magnet switch is turned on	<ul style="list-style-type: none"> - Damage or defective relays in control unit
Motor making a rattling sound	<ul style="list-style-type: none"> - Gear ring (bottom of the armature) worn out - Gear(s) worn out - No grease in gearbox
Motor humming, big sparks and motor has no force	<ul style="list-style-type: none"> - Armature damaged (burned) - Field burned - Carbon brushes worn out
Motor does not start or fails	<ul style="list-style-type: none"> - Damaged or defective wiring - Dirt in sensor control unit - Defective or loose magnet on top of armature - Damaged or defective (sensor) control unit - Damage to armature or field coil - Damaged or defective carbon brushes
Guiding takes a great deal of effort	<ul style="list-style-type: none"> - Guide is set too tight - Guide is dry, needs to be greased - Guide/gear- rack/rotation system dirty or damaged
Insufficient magnetic force	<ul style="list-style-type: none"> - Damaged or defective wiring - Bottom of magnet not clean and dry - Bottom of magnet not flat - Workpiece is not bare metal - Workpiece is not clean or flat - Workpiece is less than 6 mm (too thin) - Defective control unit - Defective magnet

Frame under voltage	<ul style="list-style-type: none"> - Damaged / defective wiring - Defective magnet - Motor seriously dirty
Fuse blows when magnet switch is turned on	<ul style="list-style-type: none"> - Damaged or defective wiring - Wrong value fuse - Defective magnet switch - Defective control unit - Defective magnet
Fuse blows when motor is started	<ul style="list-style-type: none"> - Damaged or defective wiring - Wrong value fuse - Motor running roughly - Defective armature and / or field - Carbon brushes worn out - Defective control unit
Rotation system free stroke too long	<ul style="list-style-type: none"> - Loose or defective gear rack - Defective rotation system

8. Exploded view & spare part list

8.1 Exploded view

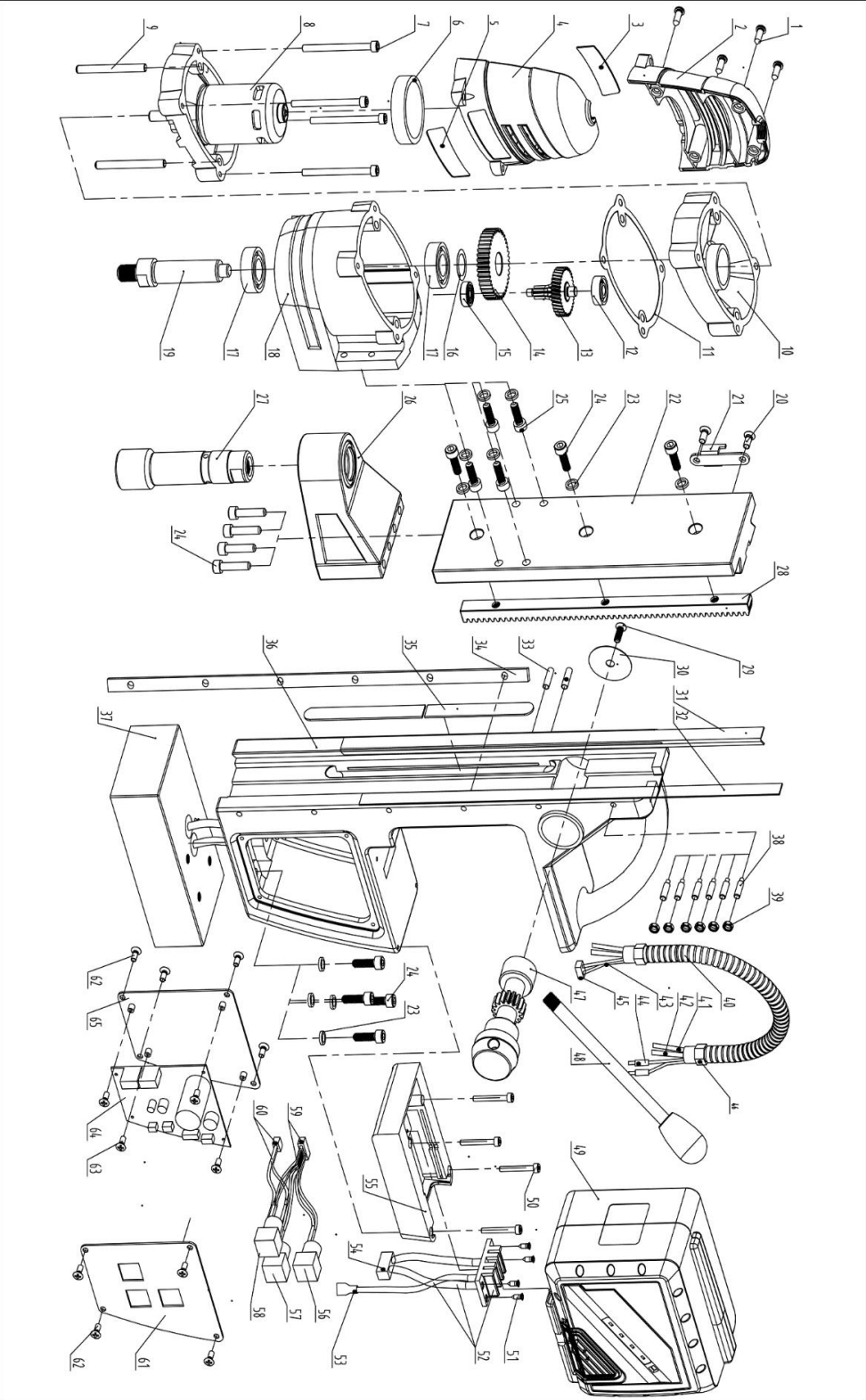

8.2 Spare part list

No	Part number	Description	Qty
1	032.0116	Screw M4 x 16	4
2	360.1002	Motorhousing left	1
3	360.1003	Label left	1
4	360.1004	Motorhousing right	1
5	360.1005	label right	1
6	360.1007	Bolt M5 x 60	4
7	360.1008	Motor unit assembly	1
8	360.1009	Pin 6 x 60	2
9	360.1010	Lower Inner gear plate	1
10	360.1011	Gasket	1
11	032.0221	Bearing 608 8 x 22 x 7	1
12	360.1013	Bevel gear assembly	1
13	360.1014	Spindle gear	1
14	360.1015	Bearing 626 ZZ	1
15	032.0191	Adapter ring 17 x 24 x 0.2	1
16	032.0196	Bearing 6003 DDU	2
17	360.1018	Gear casing	1
18	032.0201	Spindle drive shaft	1
19	KSP.M5	Screw M5 x 10	2
20	KSP.M/3	Tank holder	1
21	360.1027	Slide	1
22	020.0111	Washer M6 DIN7980	11
23	020.0156	Bolt M6 x 20	11
24	020.0106	Screw M6 x 14	4
25	360.1026	Steady	1
26	020.0116	Spindle complete 112 mm	1
27	360.1028	Rack	1
28	020.0081	End screw BKVZ M6 x 16	1
29	020.0077	End plate	1
30	360.1030	Rail set Aluminium (L/R) L-profile	1
31			
32	360.1050	Screw M5 x 25	1

No	Part number	Description	Qty
33	020.0229	Screw M4 x 20	6
33A	020.0229A	Screw M4 x 18	4
34	360.1035	Wires-Cover	2
35	360.1038	Frame 2019-05	1
36	360.1037	Magnet	1
37	020.0231	Screw M5 x 6	6
39	360.1040	Motor cable cover	1
40	360.1041	Wire connector #1 +	1
41	360.1042	Wire #2	1
42+44	360.1043	Wire connector #3 +	1
43	360.1044	Wire #4	1
45	020.0041	Coupling nut PG9 (motor cable)	2
46	020.0061/XB	Capstan hub assembly black	1
47	020.0315	Arm for capstan	3
48	360.0004	Battery pack 2.6 Ah	1
49	020.0059	Screw M4 x 25	2
50	360.1050	Bolt M4 x 30	2
51	360.1051	Screw ST2.9 x 8	4
52	360.1052	Battery contact board	1
53	360.1053	Connector	1
54	360.1054	Connector	2
55	360.1055	Battery slide base	1
56	360.1056	On switch	1
57	360.1057	Off switch	1
58	360.1058	Magnet switch	1
59	360.1059	Wire connector +	1
61	PP.F-EBM.360/2019	Front panel EBM.360/2019	1
62	020.0101	Panel screw BKVZ M4 x 8	8
63	360.1063	Screw M3 x 8	4
64	360.1064	Control-unit	1
65	PP.R-EBM.360/2019	Rear panel EBM.360/2019	1

8.3 Wiring diagram

