

User manual v.1

 **EUROBOOR**
FOR PROFESSIONALS BY PROFESSIONALS

Magnetic Drilling Machine

ECO.200

This machine is CE approved

Serial no.: _____

Date of purchase: _____

Contents

1. Before Use	1
1.1 Use Notification	1
1.2 Safety Regulations	1
1.3 Warning Symbols	3
1.4 Specification Plate	4
2. Specification	5
2.1 Function and Introduction of the Machine	5
2.2 Specification	5
2.3 Machine Dimension	6
3. Installation	7
3.1 Legend of the Machine	7
3.2 Installation Place	7
3.3 Installation Method	8
3.4 Power Supply Requirement	9
3.5 Check Connection of Power Cables	9
3.6 Test Safety Devices	9
3.7 Overall Package of the Machine	10

Contents

4. Operation Method	11
4.1 Operation Procedure	11
4.2 Control Panel	13
4.3 Emergency Stop	14
4.4 Adjustment of the Machine	14
5. Electricity	15
5.1 General Electrical Safety Regulations	15
5.2 Wiring Diagram	16
6. Maintenance	17
6.1 General Maintenance	17
7. Trouble Shooting	18
8. Appendix 1. Exploded View 1	19
Appendix 2. Exploded View 2	20
Appendix 3. Part List	21
Accessory Kit	25

1. Before Use

1.1 Use Notification

Read carefully this manual and understand all the requirements fully before operating this machine, otherwise, cutting, catching, or severe injuries may be caused.

For any part that is proven with flaws, please contact the manufacturer or the distributors within one year from the date of purchase

The manufacturer or the distributors are not obliged to repair or replace any part that has been damaged by careless operation, misuse or for any reasons, such as poor lubrication, inadequate cleaning, inappropriate operation environment, and improper operations.

1.2 Safety Regulations

- ◎ To maintain workplace safety, working regulations should be observed by every personnel in the workplace.
- ◎ The workplace should be clean and tidy.
- ◎ Do not expose the machine to dangerous environment which is prohibited for operation.
- ◎ Provide sufficient light in the workplace.

- ◎ People with pacemaker or other implanted medical devices should not operate the magnetic drilling machine as it generates electromagnetism when electric current flows through its magnetic base.
- ◎ Cleaning, greasing, checking, maintenance and other adjustment should be made to the machine only when the power cable is removed. Service should be made by qualified technicians.
- ◎ Do not leave the machine unattended while it is still running.
- ◎ The magnetic machine should be secured by fasteners as supportive device to avoid the dysfunction of the magnetic base in case of power shortage.
- ◎ It is recommended to check the machine immediately with a local technical service when the machine is not running smoothly.
- ◎ The use of cutting lubricant is recommended during the drilling process.
- ◎ Do not force small tools to perform the job of a heavy duty tool.
- ◎ Keep the machine out of reach of children.

1.3 Warning Symbols

To ensure proper and safe operation, there are six symbols showing on the machine and explaining as below. Do not remove warning symbols from the machine.

The Warning Symbols are as below :



General warning



Use earplugs



Read the manual



Wear safety shoes



Use safety goggles



Wear appropriate work clothes



Always use a safety belt when working horizontally or overhead.

Maximum cutter size 200mm diameter.

Slug ejects at the end of cut.

Use the lubricant system installed on the machine with high performance cutting oil.

1.4 Specification Plate

Voltage	1 x 230V (50/60Hz) 
Power Input	3600W
RPM	410/150
Core Drill	Ø12mm-Ø 200mm
Max. Cutting Depth	110mm
Magnetic Adhesion: 3900kg	Tool Holder: MT4

CAUTION!

Always use a safety belt when working horizontally or overhead.

Maximum cutter size 200mm diameter.

Slug ejects at the end of cut.

Use the lubricant system installed on the machine with high performance cutting oil.



General warning



Use earplugs



Read the manual



Wear safety shoes



Use safety goggles



Wear appropriate work clothes

2. Specification

2.1 Function and Introduction of the Machine

1. Highly efficient and stable drilling, offering high precision results
2. Low cutter consumption
3. Multi-purpose functions, for both drilling and tapping
4. Ergonomically designed
5. Oil bottle installed inside the housing, making it well-protected
6. Powerful and durable motor with long life expectancy
7. Waterproof and dustproof switch, ensuring safety
8. Overload protection
9. Capstan arm can be fixed on both sides of the machine
10. Control panel assembly can be fixed on both sides of the machine
11. Handle rotation offers operation positioning
12. Speed variations of motor offers the best solutions for operations on different materials and dimensions

2.2 Specification

Technical data ECO.200	
Power Input	3600W
Voltage	230V/50H/z 110V/60H/z
RPM	Two speeds High 350/150 Low 150/60
Core Drill	Φ12mm - Φ200mm
Max Cutting Depth	110mm
Twist Drill	up to φ 44mm with Morse Taper
Tool Holder	MT4
Magnetic Adhesion	3900kg
Weight	53kg

2.3 Machine Dimension

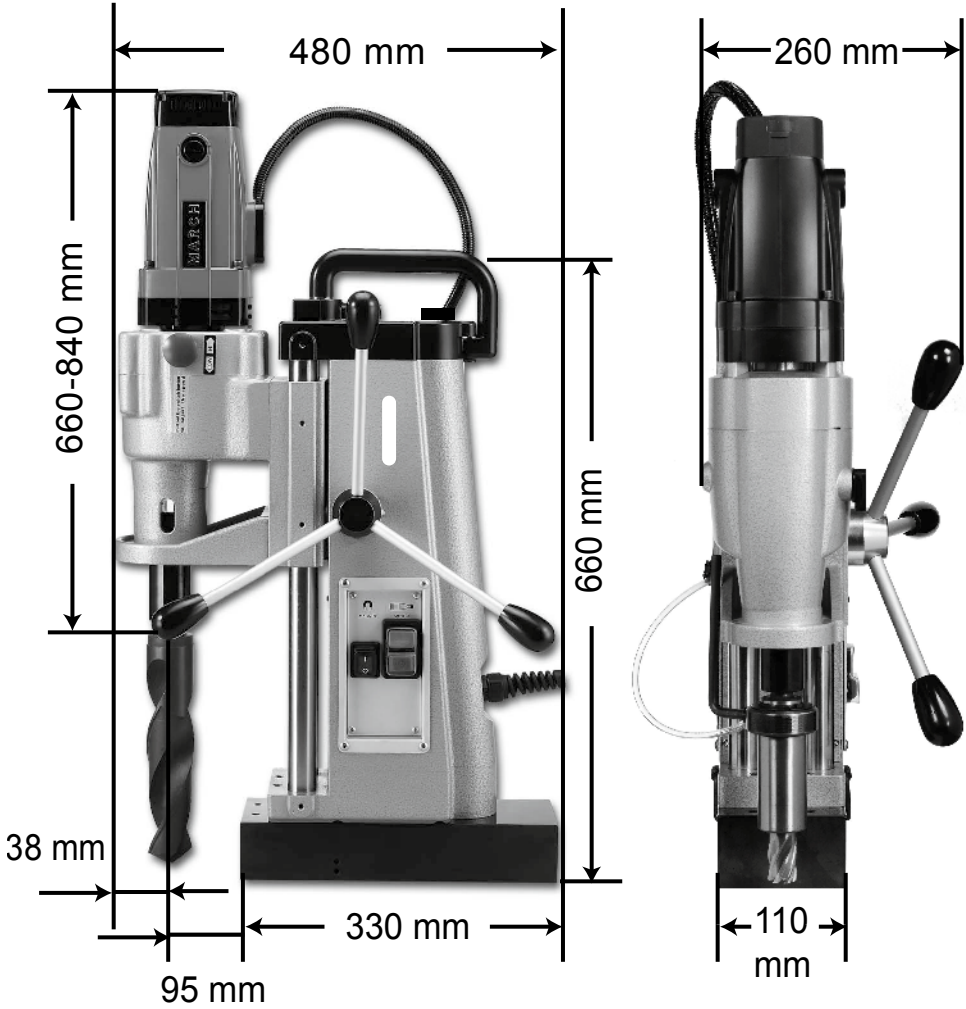

3. Installation

3.1 Legend of the Machine

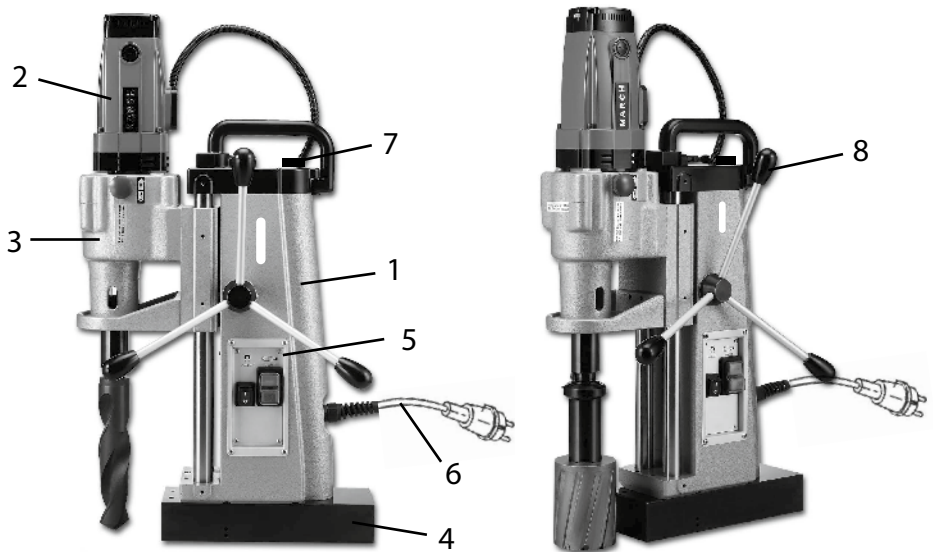

- 1. Body
- 2. Motor
- 3. Gearbox

- 4. Magnet
- 5. Control panel assembly
- 6. Main cable assembly

- 7. Oil bottle assembly
- 8. Capstan arm

3.2 Installation Place

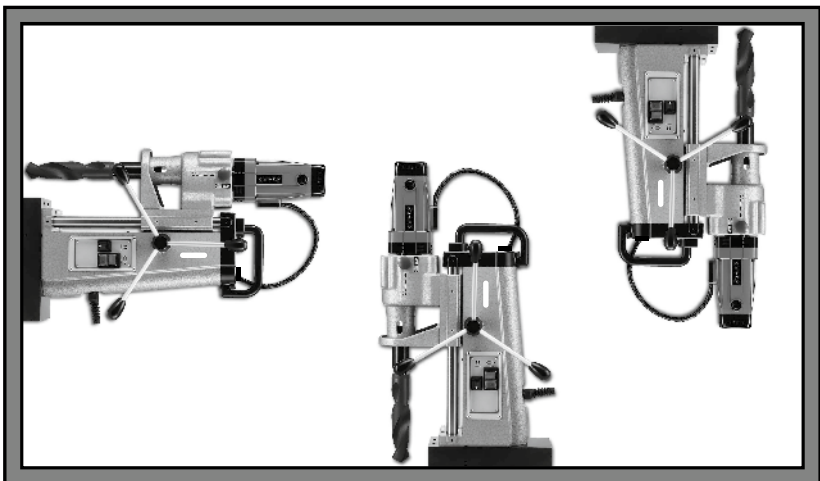

3.3 Installation Method

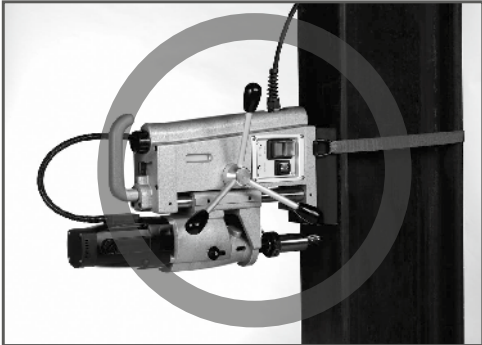
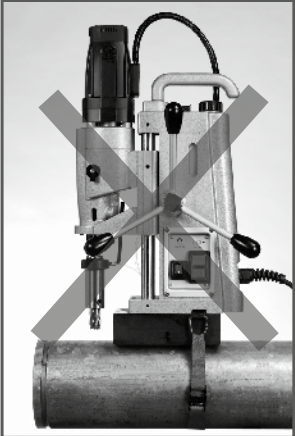
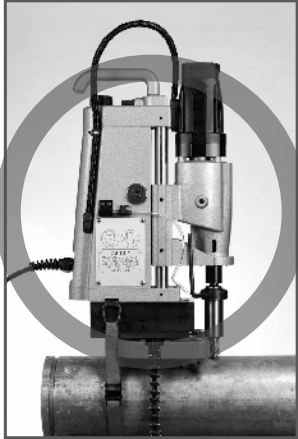

3.4 Power Supply Requirement

Inadequate voltage of the power supply at the factory may affect the output power of the motor.

It is important that this machine draws on only one separate power supply and is correctly connected to the power supply in the factory. Extended connection of power supply should be equipped with qualified leakage breaker or other safety devices.

Table for power supplies requirement:

W	Voltage	Breaker capacity	Wire size
3600	110V	26A	2mm ²
3600	230V	13A	1.5mm ²

3.5 Check Connection of Power Cables

- (1) Make sure the power supply is consistent with that making on the nameplate.
- (2) The power cable should be grounded.
- (3) Check the wires on the machine to see if there's any damage.
- (4) Check every switch to see if it is open circuited before connecting the power supply.

3.6 Test Safety Devices

The machine stop automatically when the magnetic base is turned off or the power is out.

A solenoid valve is disposed in the switch of the motor in order to prevent the machine from restarting without warning when power supply is restored after a blackout. It is necessary to push the motor switch again to operate the machine.

3.7 Overall Package of the Machine

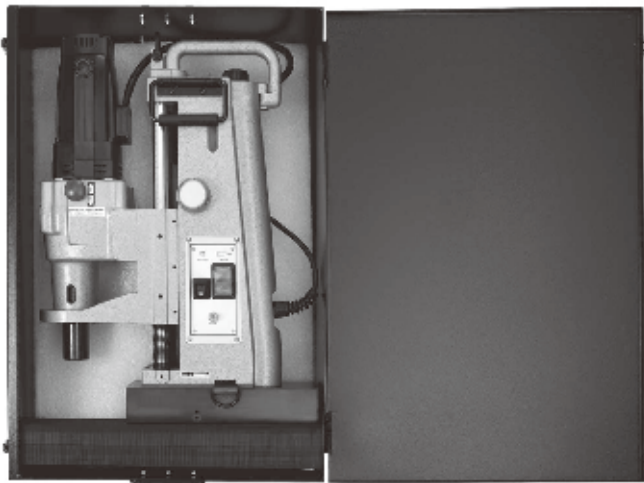

Optional metal carrying box with wheels

(We recommend using the carrying box during transportation to protect the machine)

4. Operation Method

4.1 Operation Procedure

Check the following points before starting the machine.

- (1) Before connecting the power cable, check every parts for any looseness, wire for any damage and to see if switches are all at OFF position.
- (2) Check if the specification of the power supply are consistent with the one marked on the nameplate.
- (3) The steel plates must be magnetic materials.
- (4) Check the machine base and the workpieces to see if they are flat and clean, they must be without any bump dent or foreign objects. The thickness should be larger than 10mm. Paints and other surface treatments would affect the intensity of the magnetism.
- (5) The magnetic base should fit the steel plate completely, there shouldn't be any holes.
- (6) Check the level of cutting fluid is in the usable range.
- (7) Check if the operators wear their personal protective equipment properly.
- (8) Choose a drill of suitable size and assemble it with the pin to fit on the output shaft. Use the adapter which the manufacturer provides when using a twist drill.

- (9) Mark on the working positions and adjust the machine position to align it with the marked position, and then turn the switch of the magnetic base on. (The thickness of the working pieces should be consistent)
- (10) Move the machine base by hands to check the adherence of the magnetic base; raise and lower the motor to check if the hole position is well aligned.
- (11) Turn on the switch of the cutting fluid before turning on the motor. Feed the tool slowly. When the pin pushes against the steel plate, check if the cutting fluid is flowing. During the process of drilling on the steel plate, press to feed the tool gently. Never feed hastily. When using twist drill, please prepare your own cutting fluid.
- (12) When the tools drilling through the steel plate completely, the pin pushes the chip out. (Mind the height of the working position, which should not be above the operator's head. A machine above the operator's waist should be well secured with bands; safety facility for preventing falling chips should be deployed too.)
- (13) Check the bands for their usability both before and after drilling. Replace any snapped or defective one immediately.
- (14) Turn off the power of the motor, and turn off the power of the magnetic base. Thoroughly clean the chips after process, and clean the residual cutting fluid. To resume a drilling process, repeat the above procedure to operate the machine.
- (14) Unplug the machine; clean and take anti-rust measures.

4.2 Control Panel

- 1.Magnet ON/OFF switch
- 2.Motor ON switch
- 3.Motor OFF switch
- 4.Fuse Holder

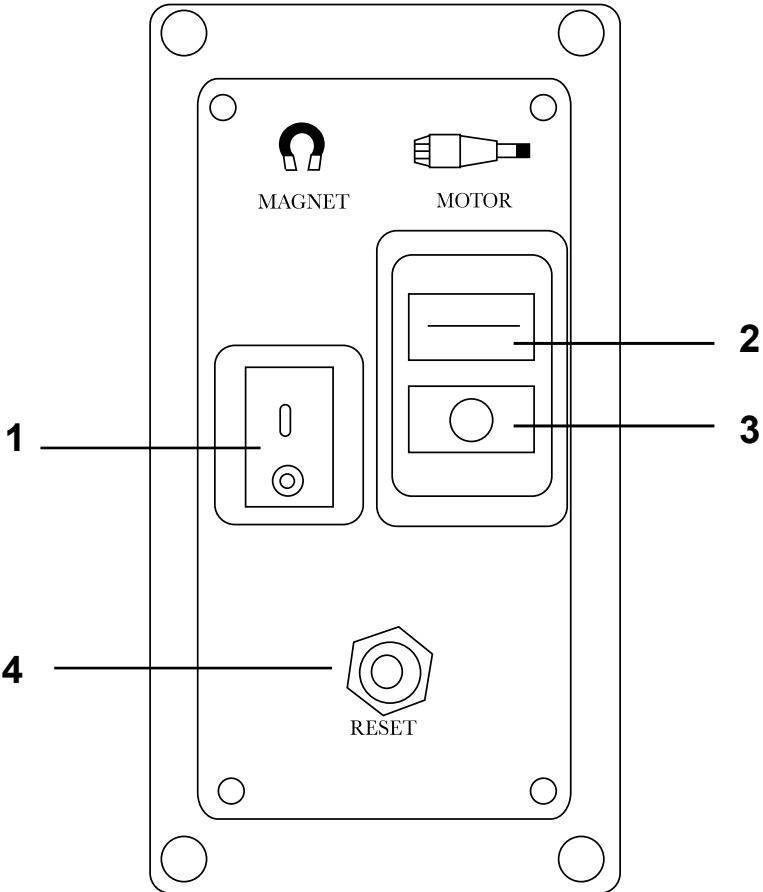

4.3 Emergency Stop

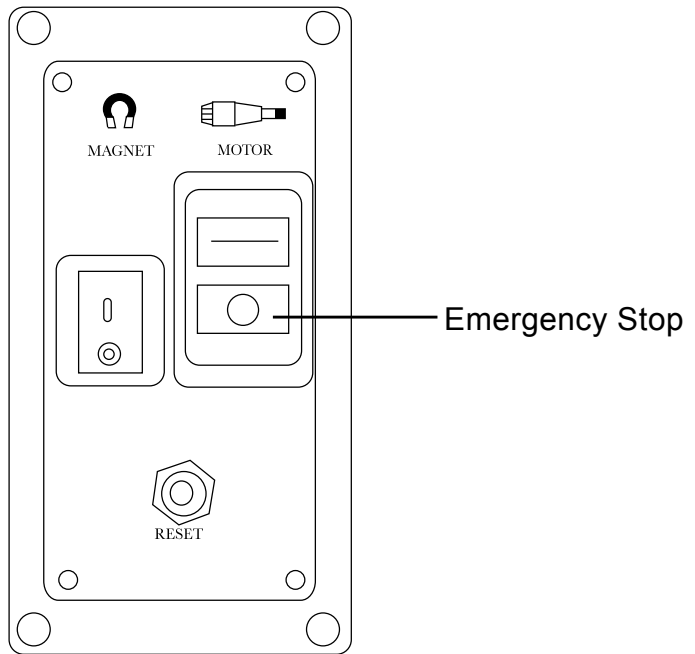

4.4 Adjustment of the Machine

Stop using the machine immediately if you find a loosen or shaking slide and rail during the operation. Adjust the gap by the following steps:

1. Loosen the bolts the rails.
2. Adjust the set screws on the right side of the machine.
(Adjust the gap between the slide and the rail.)
3. Refasten the bolts the rails after adjustment.

5 Electricity

5.1 General Electricity

1. Notify every local agency regarding the operation of the machine, so as to ensure the working environment is safe.
2. Do not operate the machine in an environment with flammable object or possible explosion.
3. Do not use the machine in wet areas to avoid electrocution
4. Never make any maintenance to the machine without removing the power cable. Maintenance can be done only by qualified technicians.
5. Never alter the circuit design in the machine.
6. Contact with a bare wire can cause severe injury or even death.
7. A wet machine or cable increases the risk of electrocution.
8. Do not join extension cords over 12m. The wires should not have a cross-sectional area greater than 1.5mm.
9. Check the power cable constantly for any damaged insulating shield. Replace the cable immediately when there is any damage.

5.2 Wiring Diagram

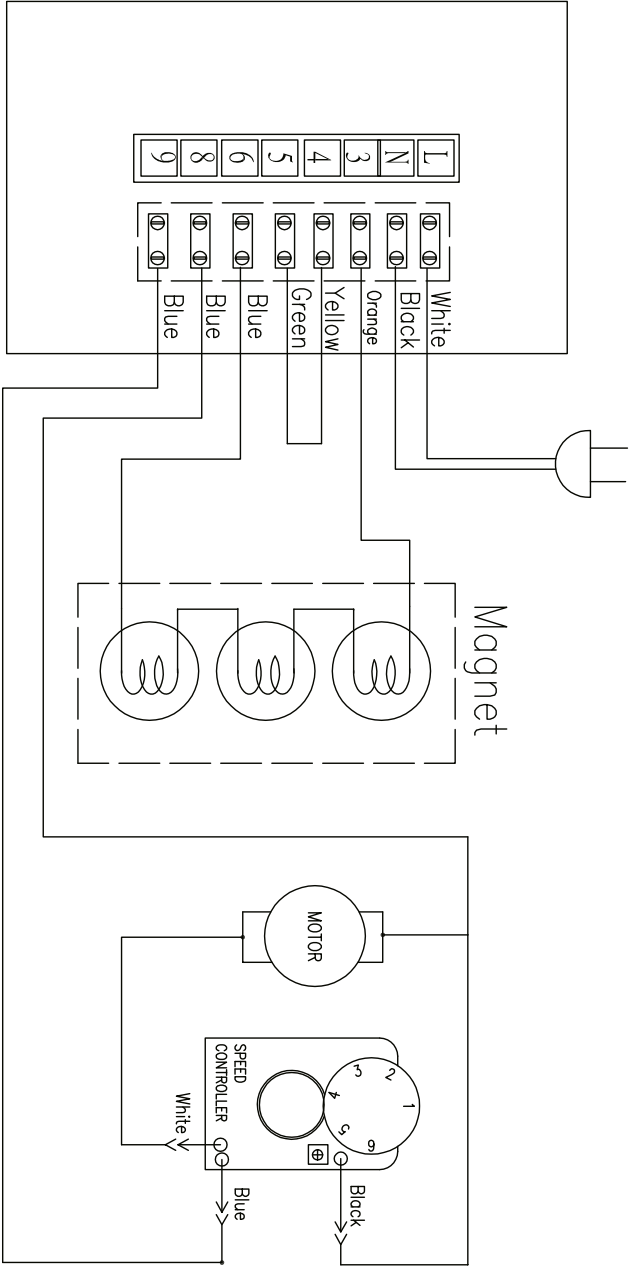

- Specifications:
- AC 115V / 26A
 - AC 230V / 13A
 - Speed 40% to Max.
- Features:
- Softstart
 - Tacho Control
 - Full wave feedback
 - Overload protection

6. Maintenance

Maintenance of the machine is recommended to keep it in an efficient state.

6.1 General Maintenance

1. Unplug the power cable before maintaining the machine.
2. Check every mechanism for anomalies. Check the bands for any snap or defect.
3. Remove the tool from the machine, clean and grease it slightly for rust resistance, and keep it in usual position.
4. Clean the chips and residual cutting fluid from the machine, the slides and links.
5. Empty the cutting fluid in the container.
6. Replace the carbon brushes immediately when they become less than 5mm in length from wearing.
7. Apply slight grease on the links of the machine and put the machine in the carrying box.

7. Trouble Shooting

Problem	Probable cause	Remedy
The motor stops during operation while the magnetic base remain functional	Overload protection device for the motor has tripped	Cool down the machine before reusing it.
	The fuse has blown from instantaneous high load	Replace with a new fuse.
The motor stops during operation while the magnetic base remain functional	The leakage breaker has tripped	Restart the leakage breaker.
	The plug comes off	Re-plug it.
	The machine is defective	Contact the manufacturer's technicians.
Leakage breaker in the distribution panel tripped	Too many machines are connected to a same power supply at the same	A power supply is used by a machine alone.
No magnetic force or insufficient magnetic force	The magnet switch is not turned on	Turn on the magnet switch
	The work place is not magnetism conductive	The machine works only magnetism conductive materials
	Defective machine	Contact the manufacturer's technicians
No lubrication by cutting fluid during the process	Lack of cutting fluid	Refill cutting fluid
	The switch of cutting fluid is not turned on	Turn on the switch of cutting fluid

8. Appendix 1. Exploded View 1

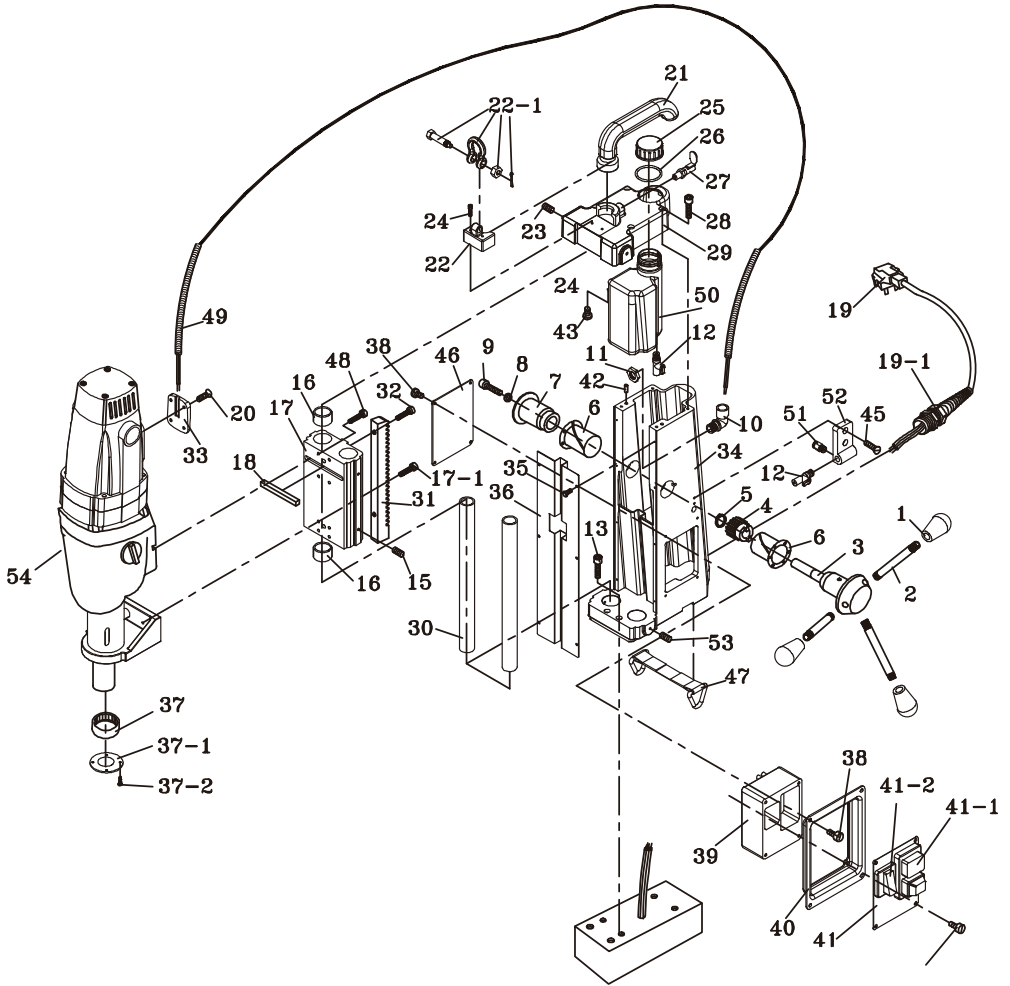

Appendix 2. Exploded View 2

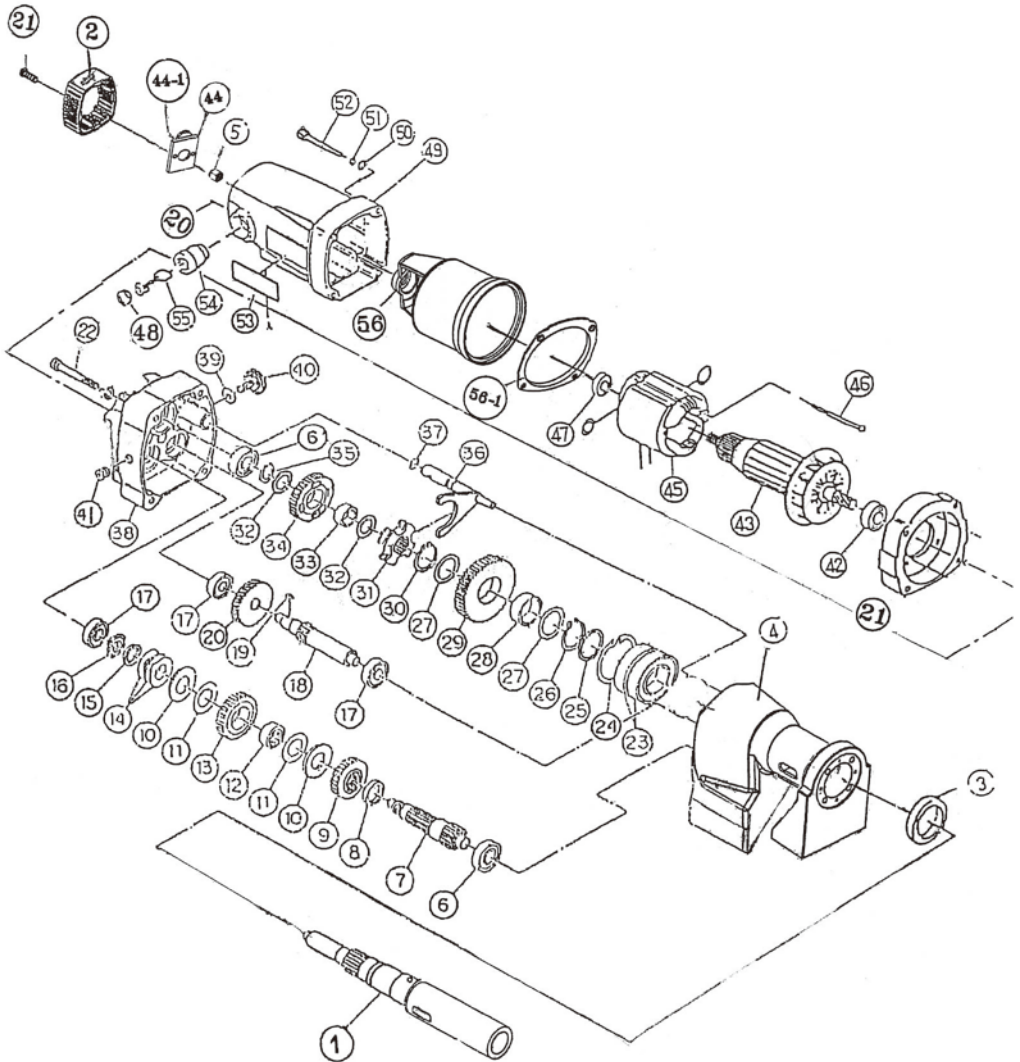

Appendix 3. Part List

ECO.200 - Complete Machine		
Part No	Component	Qty
1	Capstan ball	3
2	Capstan arm	3
3	Capstan pinion shaft	1
4	Pinion	1
5	Snap ring	1
6	Pinion bearing	2
7	Pinion shaft collar	1
8	Shakeproof washer	1
9	Socket head cap screw	1
10	Coolant elbow	1
11	Hex nut	1
12	Valve	2
13	Socket head cap screw	4
14	Magnet base	1
15	Socket set screw	4
16	Bush	4
17	Slide	1
17-1	Socket head cap screw	4
18	Key	1
19	Mains cable assembly	1
19-1	Cable fixture	1
20	Countersunk screw	4
21	Handle	1
22	Handle fixture	1
22-1	Lifting bolt	1
23	Socket set screw	2
24	Socket head cap screw	2
25	Oil bottle cover	1
26	O ring	1
27	Fixing bolt	1
28	Socket head cap screw	4
29	Housing cover	1
30	Steel tube	2
31	Rack	1
32	Socket head cap screw	2
33	Cable cover	1

Appendix 3. Part List

ECO.200 - Motor & gearbox		
Part No	Component	Qty
1	Arbor spindle	1
2	End cap	1
3	Copper spacer	1
4	Gearbox assembly	1
5	Speed sensor	1
6	Ball bearing	2
7	Third pinion (H)	1
8	Thrust washer	1
9	Spacer	1
10	Shakeproof washer	2
11	Thrust washer	2
12	Shakeproof washer	1
13	Third gear	1
14	Disk spring	3
15	Metal collar	1
16	Lock nut	1
17	Ball bearing	2
18	Second pinion	1
19	Key	1
20	Second gear	1
21	Inner cap	1
22	Screw	4
23	Ball bearing	2
24	Circlip	1
25	Metal collar	2
26	Circlip	1
27	Metal collar	1
28	Metal	1
29	Final gear (L)	1
30	Circlip	1
31	Shift ring	1
32	Metal collar	2

Appendix 3. Part List

ECO.200 - Motor & gearbox		
No	Component	Qty
33	Metal	1
34	Final gear (H)	1
35	Circlip	1
36	Shift lever	1
37	Seal	1
38	Inner gearplate	1
39	Rubber collar	1
40	Gear selector	1
41	Screw	1
42	Ball bearing	2
43	Rotor	1
44	Speed controller assembly	1
44-1	Screw	2
45	Stator	1
46	Screw	2
47	Ball bearing	1
48	Carbon brush cover	2
49	Motor housing	1
50	Metal collar	4
51	Disk seal	4
52	Socket head cap screw	4
53	Logo plate	1
54	Brush holder	2
55	Carbon brush 7x17	2
56	Aluminum bush	1
56-1	Insulation spacer	1

Accessory Kit:

Keyless ×1 pc

Safety strip ×1 pc

Hex. spanner ×1 pc

Center pin ×1 pc

Ejector pin ×1 pc