

TUBE.55s+/T

Magnetic drilling machine

EUROBOOR

FOR PROFESSIONALS BY PROFESSIONALS

Technical data

	Metric	Imperial
Annular cutting	Ø 12 - 55 mm	Ø 1/2" - 2 3/16"
Twist drilling	Ø 1 - 23 mm	Ø 1/16" - 15/16"
Countersinking	Ø 10 - 60 mm	Ø 3/8" - 2 3/8"
Tapping	M3 - M20	Ø 1/8" - 13/16"
Length	320 mm	12 5/8"
Width	210 mm	8 1/4"
Height max.	523 - 693 mm	20 9/16" - 27 1/4"
Stroke	170 mm	6 11/16"
Weight*	16 kg	35.3 lbs
Magnet (l x w x h)	275 x 190 x 90 mm	10 13/16" x 7 1/2" x 3 9/16"
Magnetic force	860 kg	1,895 lbs
Full saturation as from	12,5 mm	1/2"
Min. material thickness	3 mm	1/8"
Min. pipe diameter	80 mm	3 1/8"
Motor power	1,600 W	14.6 A
Total power	1,700 W	15.4 A
Speed		(I) 60 - 275 rpm
(no load)		(II) 100 - 500 rpm
Speed		(I) 60 - 275 rpm
(load 1,600 W, 14.6 A)		(II) 100 - 500 rpm
Spindle (Weldon)	MT3 19.05 mm	MT3 3/4"
Voltage		110 - 120 V / 60 Hz
		220 - 240 V / 50 - 60 Hz

* Without power cord and handles

Features



Adjustable speed



R/L rotation



Overload protection



Overheat protection



Power surge protection



Power fluctuation protection



Gyro-Tec



Automatic shut-off



Smart Restart



Oil lubricated gearbox



Digital display



Carbon brush wear indicator



LED load indicators



Tapping

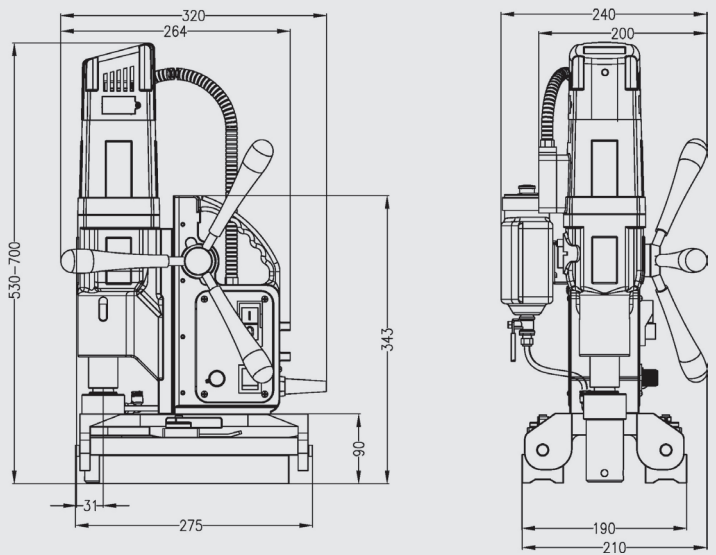

Round outer

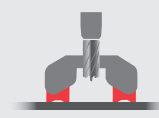

Flat surface

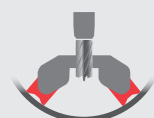

Round inner

Euroboor makes every effort to meet quality and integrity requirements. That is why we as an organization are proud of the recognition of some leading organizations worldwide:



www.euroboor.com