

PALMGREN®



13" x 19" Variable Speed Semi-Automatic Horizontal Bandsaw

Model 9683277, 230V, 3PH

®

PALMGREN

**PLEASE READ AND SAVE
THESE INSTRUCTIONS.
READ CAREFULLY
BEFORE ATTEMPTING
TO ASSEMBLE, INSTALL,
OPERATE OR MAINTAIN THE
PRODUCT DESCRIBED.**

**PROTECT YOURSELF AND
OTHERS BY OBSERVING ALL
SAFETY INFORMATION. FAILURE
TO COMPLY WITH INSTRUCTIONS
COULD RESULT IN PERSONAL
INJURY AND/OR PROPERTY
DAMAGE! RETAIN INSTRUCTIONS
FOR FUTURE REFERENCE.**

**PLEASE REFER TO BACK COVER
FOR INFORMATION REGARDING
PALMGREN'S WARRANTY
AND OTHER IMPORTANT
INFORMATION.**

Model #: _____

Serial #: _____

Purch. Date: _____

**© 2024 Palmgren – a C.H. Hanson Company
All Rights Reserved**

GETTING STARTED

Save this manual

You will need this manual for the safety warnings and precautions, assembly instructions, operating and maintenance procedures, parts lists and diagrams. Keep your invoice with this manual. Write the invoice number on the inside of the front cover. Keep this manual and invoice in a safe and dry place for future reference.

Structural requirements



Make sure all supporting structures and load attaching devices are strong enough to hold your intended loads. If in doubt, consult a qualified structural engineer.

Electrical requirements



The power supply to the 9683277 bandsaw must be 230 VAC, 3-phase, 60 Hz.

The standard allowable voltage variation is $\pm 10\%$.

Tools needed

Standard professional mechanic's hand tool set.

UNPACKING

Unpack

When the bandsaw is delivered, please check immediately that it has not been damaged during transport. Transport the bandsaw in its packing crate near its final installation site before unpacking it. If the packaging shows signs of possible transport damage, take the necessary precautions to avoid damaging the machine when unpacking.



Do not discard packing materials until after bandsaw has been inspected for damage and completeness. Locate loose parts and set aside.

Inspect



After unpacking, carefully inspect the bandsaw for any damage that may have occurred during transit. Check for loose, missing, or damaged parts. Notify the carrier immediately; shipping damage claims must be filed with the carrier. Immediately report any missing parts to the dealer.

- Be sure that the voltage labeled on the machine matches your power supply.
- Inspect the machine completely and carefully, making sure that all materials, such as shipping documents, manuals and accessories supplied with the machine have been received.
- Also check that no fastening screws have come loose. Compare the scope of delivery with the attached packing list.
- All tools should be visually inspected before use, in addition to regular periodic maintenance inspections.

SAFETY RULES

Before repairs, powering on the machine or maintenance, the user must know and follow all safety guidelines.

Clothing and General Use

▲ WARNING

- For your own safety, read all of the instructions and precautions before operating tool.
- Always follow proper operating procedures as defined in this manual even if you are familiar with the use of this or similar tools. Remember that being careless for even a fraction of a second can result in severe personal injury.
- Wear proper apparel. Do not wear loose clothing, gloves, neckties, rings, bracelets, or other jewelry which may get caught in moving parts of machine.
- Wear protective hair covering to contain long hair.
- Wear safety shoes with non-slip soles.
- Wear safety glasses complying with United States ANSI Z87.1. Everyday glasses have only impact resistant lenses. They are NOT safety glasses.
- Wear face mask or dust mask if operation is dusty.
- Be alert and think clearly. Never operate power tools when tired, intoxicated or when taking medications that cause drowsiness.
- Work area should be properly lighted.
- Keep visitors at a safe distance from work area.
- Keep children out of workplace. Make workshop childproof. Use padlocks, master switches or remove switch keys to prevent any unintentional use of power tools.
- **PROPOSITION 65 WARNING:** Some dust created by using power tools contain chemicals known to the state of California to cause cancer, birth defects or other reproductive harm. Some examples of these chemicals are:
 - Lead from lead-based paints.
 - Crystalline silica from bricks and cement and other masonry products.
 - Arsenic and chromium from chemically-treated lumber.

Your risk from these exposures varies, depending on how often you do this type of work. To reduce your exposure to these chemicals: work in a well-ventilated area and work with approved safety equipment. Always wear OSHA/NIOSH approved, properly fitting face mask or respirator when using such tools.

Installation Safety**▲ WARNING**

- Ensure the installation location can support the weight of the machine and has adequate space, ventilation, and heat dissipation.
- Do not allow water or other liquids, dust, metal dust or other contaminants to enter the controls or electrical box, it may cause fires or damage to the machine and surroundings.
- Do not make any changes or modifications to the machine; this could cause an electric shock or personal injury and void the warranty.

▲ CAUTION

- When moving to the install location make sure the bandsaw is firmly secured to the lifting means. Use the appropriate means to place the machine in the desired location for use.
- Ensure the machine is level before using.

Electrical Safety

▲ WARNING *All electrical connections must be done by a qualified electrician! Failure to comply may result in serious injury.*

- Make sure wiring codes and recommended electrical connection instructions are followed and that machine is properly grounded.

▲ WARNING *Before connecting power source, check that the bandsaw power switch is off.*

Maintenance Safety

- Always ensure bandsaw is powered off prior to inspection, maintenance, or repair.
- Consult manual for specific maintaining and adjusting procedures.
- Only a qualified electrician should check the electric parts.
- Keep bandsaw lubricated and clean for safest operation.
- Remove adjusting tools. Form habit of checking to see that adjusting tools are removed before switching machine on.
- Keep all parts in working order. Check to determine that guards and other parts will operate properly and perform their intended function.
- Check for damaged parts. Check for alignment of moving parts, binding, breakage, mounting and any other condition that may affect a tool's operation.
- A guard or other part that is damaged should be properly repaired or replaced. Do not perform makeshift repairs. (Use parts list provided to order repair parts.)

Know How To Use Tool

- Use right tool for job. Do not force tool or attachment to do a job for which it was not designed.
- Do not force tool. It will work most efficiently at the rate for which it was designed.
- Use of improper accessories may cause risk of injury to persons.

▲ CAUTION *Think safety! Safety is always a combination of operator common sense and alertness when tool is being used.*

Operating Safety

▲ WARNING *Before starting machine check:*

- KEEP GUARDS IN PLACE AND IN WORKING ORDER.
 - KEEP WORK AREA CLEAN. Cluttered areas and benches invite accidents.
 - NEVER USE IN DANGEROUS ENVIRONMENT. Do not use power tools in damp or wet locations, or where any flammable or noxious fumes may exist. Do not expose power tools to rain. Keep work area well lighted.
 - NEVER FORCE TOOL. It will do the job better and safer at the rate for which it was designed.
 - USE THE RIGHT TOOL. Do not force tool or attachment to do a job for which it was not designed.
 - If you are not familiar with the operation of horizontal band saws, obtain advice from your supervisor, instructor or other qualified person before using saw.
 - Always turn power off before making any adjustments.
 - Adjust and position the blade guide before cutting.
 - Ensure that blade tension is properly adjusted before cutting.
 - Always provide adequate support for long and heavy material.
 - Never hand hold the material. Always use the vise and clamp it securely.
 - Stop the saw before putting a workpiece in the vise. Ensure stock is firmly clamped in vise before cutting.
 - Handle workpiece correctly. Protect hands from possible injury. Keep hands away from moving parts and surfaces.
 - Never leave bandsaw running unattended. Turn power off and do not leave tool until it comes to a complete stop.
 - Do not overreach. Keep proper footing and balance.
 - Never stand on tool. Serious injury could occur.
 - Clean dust/chips frequently. Stop the saw before cleaning. Before leaving the machine, make sure the work area is clean
- ▲ CAUTION**
- Do not repeatedly turn the power switch on and off in a short amount of time. This will damage the machine.
 - Please treat the debris generated during processing as industrial waste to prevent environmental pollution or personal injury.

SPECIFICATIONS

Description	Palmgren Variable Speed Horizontal Bandsaw 13" x 19"
Model number	9683277
Voltage	230 VAC, 3-phase
Amperage	8A
HP	3 HP Motor
Phase	3-phase, 230 VAC
RPM	1720
Blade Dimensions	1.25" x 0.043" x 161.5"
Blade speeds	80-250 SFPM
Capacity: 90° Round	13"
Capacity: 90° Square	13" x 19"
Capacity: 90° Flat	9" x 21"
Capacity: 45° Round	10"
Capacity: 45° Square	11" x 10.5"
Coolant volume	6.5 Gallons
Height of Table Vise	28.5"
Machine Dimensions	90" L x 35" W x 59" H
Weight	Crated: 1,521 lbs Uncrated: 1,323 lbs

Blade Selection







Never use a blade so coarse that less than 3 teeth are engaged in the workpiece at a time. Too few teeth causes teeth to strip out.

Never use a blade finer than needed to obtain a satisfactory surface finish or satisfactory flatness. Too many teeth slows down the sawing rate; can cause premature blade wear; and frequently produces "dished" cuts or cuts that are not square nor parallel.

NOTE:

- When cutting standard wall pipe, tubes, channel iron, angle iron, and I-beam, a 10 pitch (number of teeth per inch of blade) saw blade of wave-set type or sawblade of (HSS) 6/10T is commonly used.
- Tubing or structure with wall thickness or web thickness of 1/2" or more is usually cut satisfactorily using an 8 or 6 pitch sawblade of (HSS) 4/6T.
- When sawing rectangular solid bar, the work should, whenever possible, be loaded with the thinnest cross section exposed to the blade teeth. The pitch selected must provide engagement of at least 3 teeth in the workpiece. If this is not possible because the thinnest cross section is too thin, then load the piece with the wider dimension exposed to the saw teeth and use a coarser blade intended for cutting round and square solid bars.

The chart provided here is a general guide. Consult with your blade supplier or qualified engineers for information on saw blades. **HSS**=High Speed Steel; **HCS**=High Carbon Steel

	Material Shape						
	Material Diameter	<0.12"	>0.2"	>2"	>4"	>6"	>8"
Sawblade	(HSS) 14T	●					
	(HSS) 6/10T		●				
	(HSS) 5/8T			●			
	(HSS) 4/6T			●	●		
	(HSS) 3/4T				●		
	(HSS) 2/3T					●	●
	(HSS) 1/2T						●
	(HCS) 10T	●					
	(HCS) 8T		●				
	(HCS) 6T			●			
	(HCS) 4T				●		
	(HCS) 2T					●	●

INSTALLATION

Moving Bandsaw

The bandsaw must be installed on a solid, level foundation. Choose a location that allows room for servicing and for moving large stock around the bandsaw.

⚠ WARNING *Severe or fatal injuries may occur if the machine is moved improperly. Follow the instructions and information on the transport crate. Check that the lifting and load suspension equipment has sufficient load capacity and that it is in perfect condition.*

⚠ WARNING *The total weight of the crated bandsaw is 1,521 lb. Use only transport and load suspension devices that can hold the total weight of the bandsaw.*

**Fasten the load properly.
Never walk under suspended loads!**

- Move bandsaw to desired location as follows:
 - If moving with a lifting strap, remove all bolts attaching machine to shipping base. Leave packing material between vise clamps and saw head in place until bandsaw has been lifted to its final position. See Figure 1 (left) for strap placement.
 - Using lifting straps that are isolated from the bandsaw's finished surfaces. If moving with a forklift, orient the bandsaw on forklift as, shown in Figure 1 (right). Keep the bandsaw balanced when moving it. Consider the center of gravity. Drive forklift slowly and carefully.
- Position the bandsaw in the desired location. Ensure there is access to the electrical panel and that the panel is located close to the 230 VAC power source.

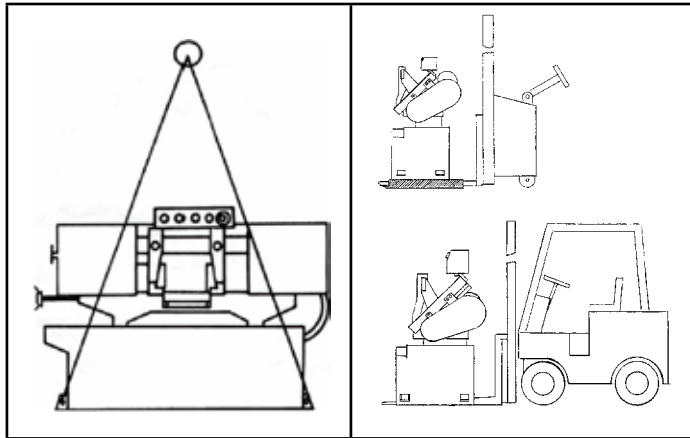

Figure 1. Moving Bandsaw: Straps (Left) or Forklift (Right)

Mounting and Leveling

- Install 4 leveling bolts with lock nuts on both sides of base.
- Place a level on the table surface and check side to side and front to back.
- Adjust leveling screws until machine is level in both directions and tighten locking nuts.
- Rust inhibitor was applied to the machined surfaces at the factory. Clean the rust inhibitor off using a soft cloth lightly dampened with WD-40.

Assembly

Insert stop rod in to the base below the vise. Place work stop bracket onto stop rod and tighten lock handle. Attach stop screw to stop bracket with lock handle and tighten.

Electrical Wiring

The bandsaw is rated and prewired at 230V, 3-Phase. Confirm power available matches the saw's wiring.

NOTE: The bandsaw must always be correctly grounded.

See Figure 2 for the schematic. Connect the bandsaw to the electrical source as shown. Refer to the wiring diagram inside the electrical box for proper motor and transformer connections, lead selection and wiring connections from motor to power source.

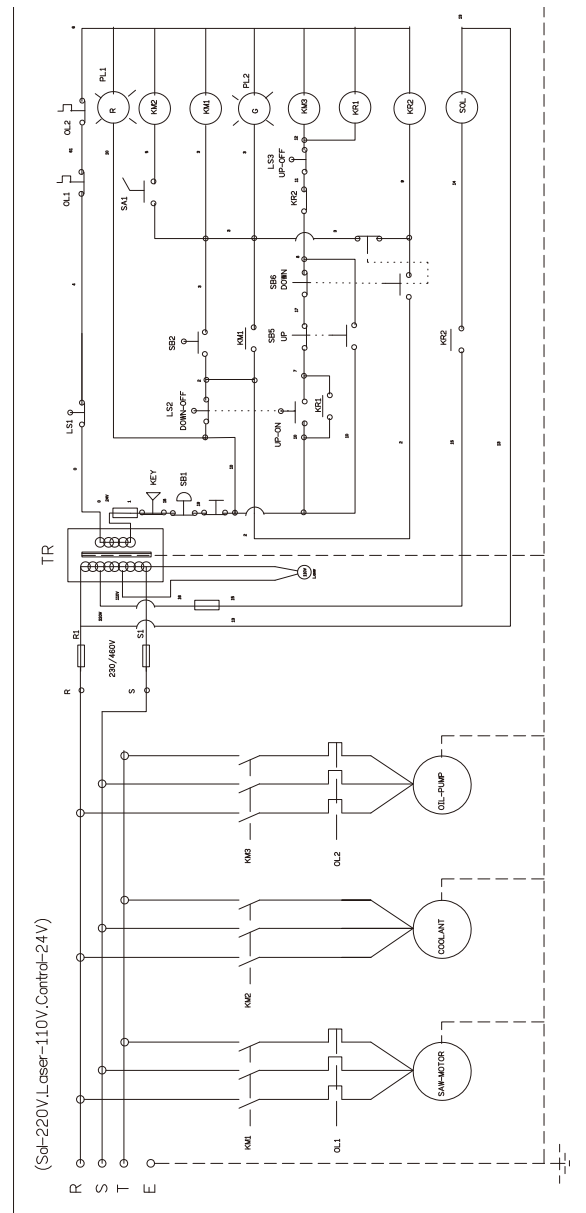

Figure 2. 230V Wiring Diagram

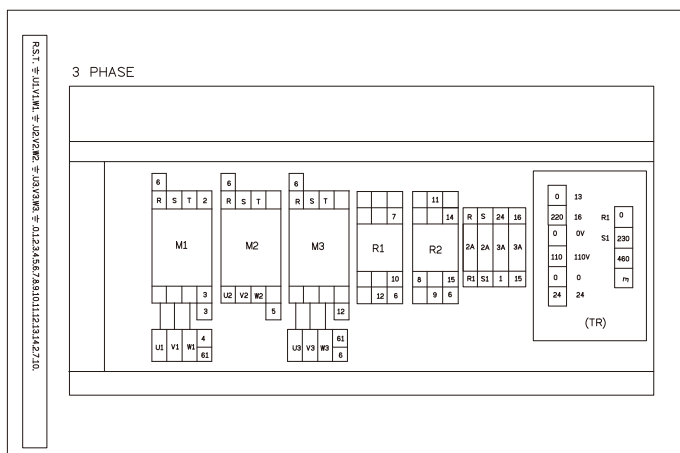
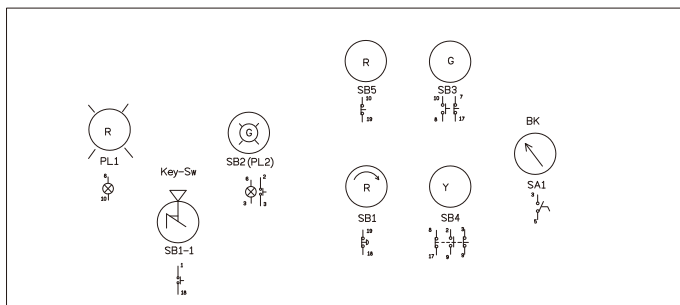

Figure 3. Electrical Panel Layout

Coolant

Add 6.5 gallons of water-soluble coolant/cutting fluid before operating bandsaw.

OPERATION

Controls – See Figure 4

- A Power Indicator Light:** lit whenever machine is running.
- B Start Button:** press to start bandsaw.
- C Stop switch:** press to stop bandsaw.
- D Emergency Stop Button:** press to immediately stop all machine functions.
- E Bow-up Switch:** press to raise bow.
- F Bow-down Switch:** press to lower bow.
- G Coolant Switch:** select “I” to start coolant pump. Select “O” to stop coolant flow.
- H Cutting Pressure Control:** turn clockwise to increase cutting pressure. Turn counter-clockwise to decrease cutting pressure.

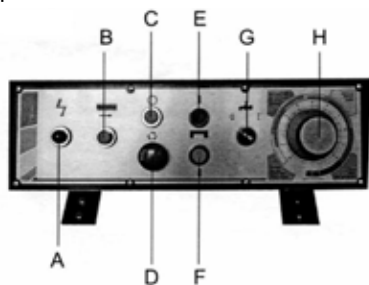

Figure 4. Bandsaw Controls

Materials and Speeds

Refer to Figure 5. The Cutting Pressure Control provides a guide to the best setting range to use for materials of different hardness.

- A (Light blue):** Hard Metals
- B (Green) -** Medium Hard Metals
- C (Yellow):** Soft Metals
- D (Orange):** Soft Materials)
- E (Blue-Red):** Rapid Down Feed

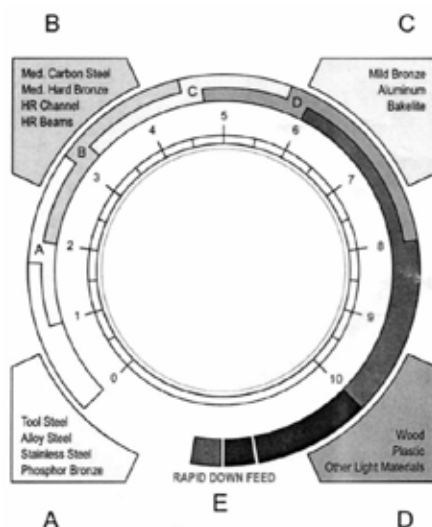

Figure 5. Material/Speed Guide

Before Operating

1. Check that the blade tooth direction matches diagram on blade guides.
2. Check that blade is properly seated on wheels after applying correct tension (approximately 25,000 lbs).
3. Set blade holder guides for approximately .003” to .005” clearance between the guides and blade.
4. Check for slight clearance between backup rollers and back of blade.
5. Position blade guides as close to the workpiece as possible.
6. Select proper speed and feed rate for material being cut.
7. Ensure material to be cut is securely held in vise.
8. Do not start cut on a sharp edge.
9. Keep machine lubricated. See “Lubrication” on page 12.

Adjusting Vise Square to the Blade

1. Disconnect the machine from the power source.
2. Place a machinist’s square on the table against the blade and the vise (fixed). The square should lie along the entire length of the Vise and blade without a gap.
3. If adjustment is necessary, loosen bolts holding the vise and adjust vise so square lines up properly. Tighten bolts.
4. Reconnect machine to the power source.

PALMGREN

Changing Blade Speed

NOTE: Bandsaw must be running in order to adjust blade speed.

The dial protruding from the motor cover (right side) controls the speed between 66 FPM to 264 FPM.

Rotate the speed control (Figure 6, **A**) by following the level (**B**) in the scale to set desired speed for cutting the workpiece.

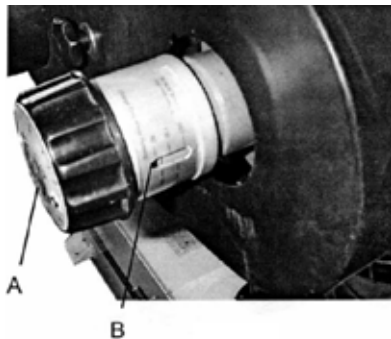

Figure 6. Speed Adjustment Control

Adjusting Feed Rate

Feed rate is adjusted by turning the cutting pressure control knob on the control panel.

Feed rate is important to bandsaw performance; excessive pressure may break the blade or stall the saw. Insufficient pressure rapidly dulls the blade.

Chips are a good indicator of proper speed and pressure. The ideal chip is thin, tightly curled, and warm to the touch.

- Chips that range from golden brown to black indicate excessive force.
- Blue chips indicate extreme heat from too high a blade speed, which will shorten blade life.
- Thin or powdered chips indicate insufficient feed pressure.

Semi-Automatic Bow

The user presets the height at which the bow stops when it raises automatically. Bow height depends upon the piece to be cut. See Figure 7. The limit switch is lowered or raised by loosening a locking knob (**A**). Tighten the locking knob when the limit switch **B** is properly adjusted. The scale (**E**) allows the user to position the bow height from 0 to 13" above the bed. The saw arm will automatically return to the preset level when after the cut.

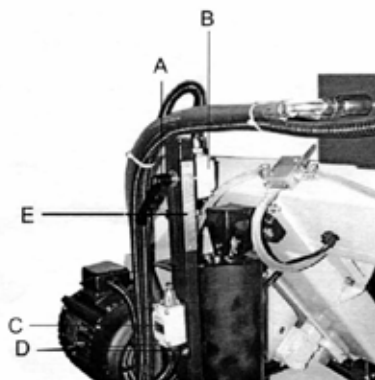

Figure 7. Bow Height Settings

Down-Bow Dampener

To produce a better cut, this bandsaw reduces the rate of down-bow when the blade approaches the table. The saw is equipped with a standard (inch) size blade at the factory. Because the width of standard size and metric size blades are slightly different, using a metric-sized blade requires adjusting the dampener by turning the cap screw (Figure 8, **A**) clockwise about 1-1/2 revolution. The limit switch must also be adjusted (Figure 7, **C**). Otherwise, the bow will not automatically raise after completing the cut.

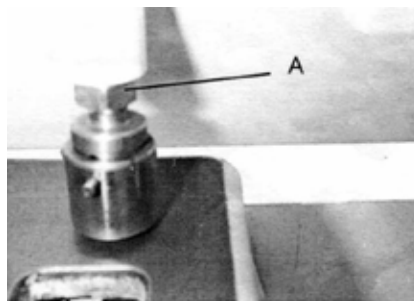

Figure 8. Down-Bow Dampener Adjustment

Starting and Stopping the Bandsaw

The saw frame must be in the raised position before starting the machine. The machine is started by pushing the start button (Figure 4, **B**), and it will continue to run until the saw frame is in the down position at the end of the cut, or when stop button (**C**) is pressed. Pressing the stop button stops the motor at any time.

Automatic Shut-Off

The blade will stop after the material has been cut and the bow reaches its lowest position. The bow will automatically raise to the preset height.

NOTE: If the bow or blade fails to stop, limit switch (Figure 7, **C) must be raised.**

1. Loosen 2 screws (Figure 7, **D**).
2. Lift limit switch to desire height.
3. Tighten 2 screws.

Coolant Pump

The coolant pump (Figure 9) provides a flow of coolant to the bandsaw blade during cutting. It is also used for the chip cleaner attachment. The coolant tank requires 6.5 gallons of water-soluble cutting fluid.



Figure 9. Coolant Pump

Cleaning Chips

The chip cleaner attaches to the coolant pump and is stored in the front locker (Figure 10, **A**). To operate, open valve (Figure 9, **A**) and use hand nozzle to spray (Figure 10, **B**).

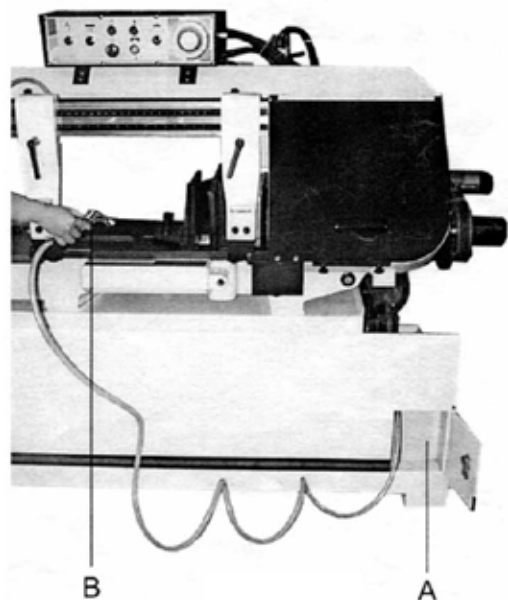

Figure 10. Chip Cleaner

TROUBLESHOOTING

⚠ WARNING *Make certain that the bandsaw is disconnected from power source before attempting to service or remove any component.*

Symptom	Possible Causes	Corrective Action
Foaming coolant, high blade temperature	Low coolant	Check coolant and add if necessary.
No coolant when cutting.	1. Low coolant or clogged coolant pump 2. Coolant pump motor not working	1. Add coolant to a level above the pump. 2. Remove coolant pump motor to clean/repair it.
Clogged pump	Dirty or weak coolant	Replace coolant with 6.5 gallons of water-soluble cutting fluid.
Crooked cuts	Dirty or weak coolant	Replace coolant with 6.5 gallons of water-soluble cutting fluid.
Slow cutting rate	Dirty or weak coolant. Dirty coolant may also cause the growth of bacteria with possible skin irritation resulting.	Replace coolant with 6.5 gallons of water-soluble cutting fluid.

MAINTENANCE

Changing the Blade

⚠ WARNING *Make certain that the bandsaw is disconnected from power source before attempting to service or remove any component.*

A blade is installed in the saw at the factory. When selecting a new blade refer to the selection of sawblades. The bandsaw requires a blade 1.25" x 0.043" x 161.5".

To replace the blade:

1. Raise the saw arm approximately 6". Press the emergency stop button to hold the arm in place.
2. Disconnect machine from power source.
3. Open both wheel covers and clean chips out of both wheel housings. Loosen lock knobs and remove upper and lower blade guard. Remove wire brush assembly.
4. Release blade tension by turning blade tensioning handwheel (Figure 11, **A**) counter-clockwise until blade is free.
5. Loosen lock knob and slide left blade guide arm (**B**) to the right as far as possible.
6. Remove old blade from both wheels and out of each blade guide.

PALMGREN

⚠ WARNING *Even dull blades are sharp to the skin!
Use extra caution handling bandsaw blades!*

- Install new blade, ensuring teeth point downward in the proper cutting direction. If necessary, turn blade inside out.
- Position blade on band wheels and tighten just enough to hold blade on wheels. Make sure back of blade rests lightly against the wheel flange of both wheels. Twist blade slightly to allow it to slip into guides.
- Tension blade to approximately 25,000 lb. Blade tension is indicated on the tension wheel shaft housing (left side).
- Attach wire brush to the wire brush post with screw and washer. Adjust wire brush post so that brush just comes into contact with blade teeth.
- Close all covers and guards and fastened securely. Connect machine to power and run freely for approximately two minutes.
- Turn power off and recheck blade tension and wire brush adjustment. If further adjustment is necessary, disconnect saw from power source, make adjustments, and reconnect power.
- Reconnect the power source. Briefly turn the power "on" and "off" to be sure the blade is in place and tracking properly. If blade is not tracking properly refer to "Blade Tracking Adjustment" on page 10.

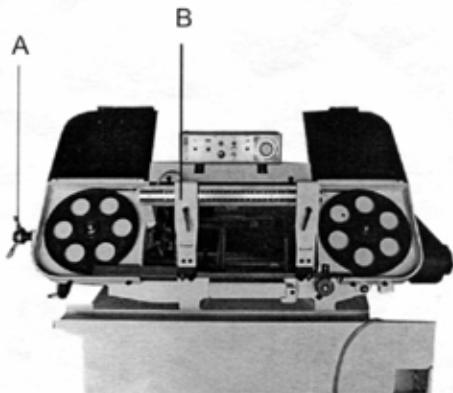

Figure 11. Blade Tensioning Handwheel

Chip Brush

The chip brush may need periodic adjustment due to normal everyday wear.

- Disconnect machine from the power source.
- Open the right side wheel cover.
- Loosen bolts (Figure 12, **A**).
- Raise the chip brush so that it touches the blade.
- Tighten bolts (**A**).
- Close wheel cover.
- Connect machine to power source.

NOTE: Replace the chip brush if it no longer reaches the blade.

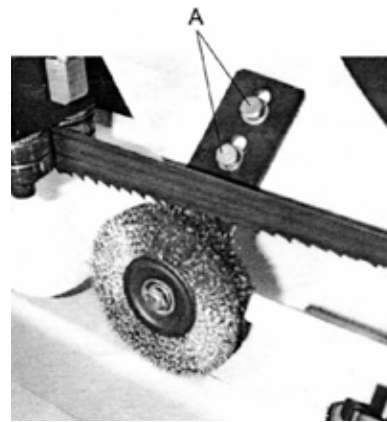

Figure 12. Chip Brush

Chip Hole

The chip hole (Figure 13, **A**) may require periodic cleaning if the hole becomes clogged with chips and debris.

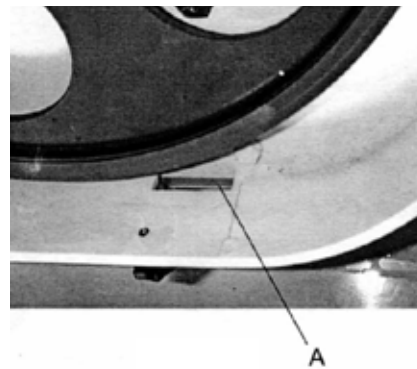

Figure 13. Chip Hole Location

Blade Tracking Adjustment

Blade tracking has been set at the factory and should not require adjustment. If a tracking problem occurs, adjust the machine as follows:

⚠ WARNING *Tracking adjustment is done with the wheel covers open to observe the blade. Use extreme caution so as not to come into contact with the blade while wheel covers are open.*

⚠ WARNING *Never cut material when the wheel covers are removed.*

Because tracking can only be adjusted while machine is running, it is suggested that this adjustment be accomplished by qualified personnel familiar with this type of adjustment and the dangers associated with it.

- Disconnect the power source.
- Raise saw arm to its highest position.
- Locate tracking adjustment plate on the back of the idle wheel.
- See Figure 14. Loosen 3 bolts (**A**) on the top of the tracking nuts. Tracking adjustment is accomplished by either loosening or tightening three adjusting nuts (**B**). Tracking is set properly when the back of the blade slightly touches the wheel flange.

NOTE: Over-tracking (allowing blade back to rub hard against wheel flange) will damage the blade wheels and blade.

5. Tighten locking bolts (A) when tracking adjustment is completed.
6. Reconnect machine to the power source.

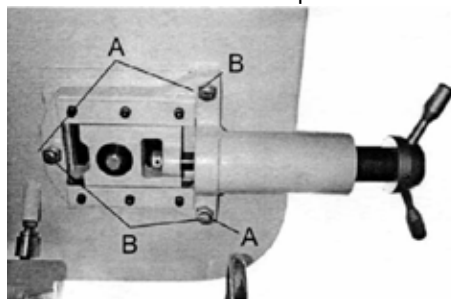

Figure 14. Blade Tracking Adjustment

Automatic Shut-Off Adjustment

The motor should shut off immediately after the blade has cut through the material and just before the head comes to rest on the horizontal stop bolt. If the machine continues to run after the workpiece has been fully cut, locate and adjust the hydraulic valve mounting plate down. If the machine shuts off before the workpiece has been completely cut, move the hydraulic valve mounting plate up.

Thrust Roller Adjustment

1. Disconnect machine from the power source.
2. Loosen two hex socket cap screws (Figure 15, A).
3. Move guide seat (B) up or down until a clearance of 0.003" to 0.005" between back of blade and thrust roller is obtained.
4. Tighten two hex socket cap screws (Figure 15, A).
5. Repeat for other blade guide assembly.
6. Reconnect machine to power source.

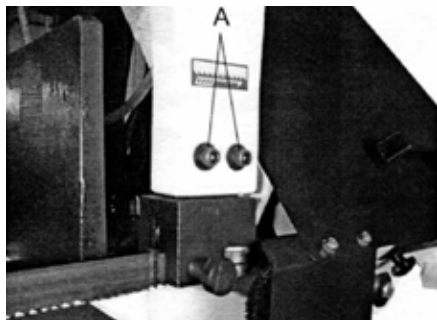

Figure 15. Thrust Roller Adjustment

Guide Roller Adjustment

NOTE: In Figure 17, only bearing A is adjustable. Bearing B is fixed.

1. Disconnect machine from the power source.
2. Loosen blade guides by loosening guide adjustment screw (Figure 16) and hex socket cap screw (Figure 17, A).
3. Slide blade guides away from blade.
4. Adjust the eccentric bushings with a combination wrench until the ball bearings are snug to the blade (Figure 17, A).

NOTE: Blade should travel freely up and down between the ball bearings. Do not pinch the blade.

5. Tighten locking screws (Figure 17, A).
6. Slide blade guides back into contact with blade and tighten thumb screw (Figure 16) and hex socket cap screw (Figure 17, A).
7. Reconnect machine to the power source.

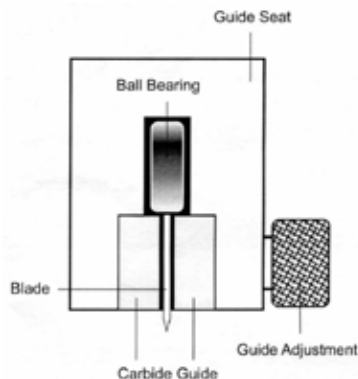

Figure 16. Guide Roller Adjustment

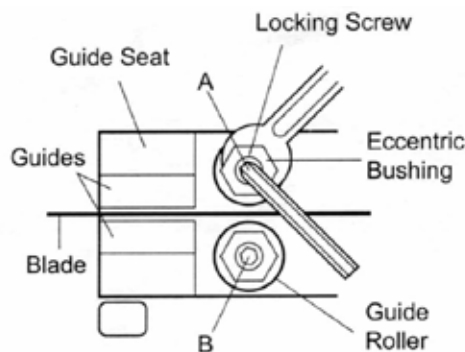

Figure 17. Guide Rollers

Vise Adjustment

To position the movable vise jaw:

1. See Figure 18. Turn vise handwheel (A) 1/2 turn counter-clockwise.
2. Move rack block (B) to desired location by sliding along the bed. Place the rack block onto the rack.
3. Turn the handwheel to tighten the vise.

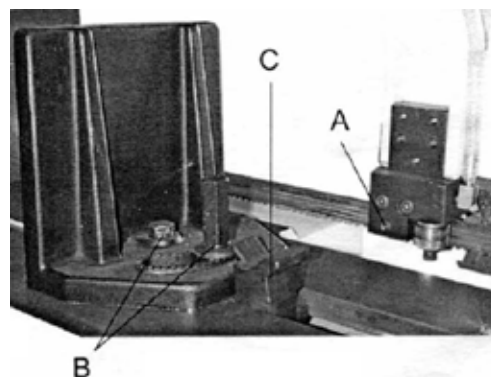

Figure 18. Vise Adjustment

To adjust vise for angle cutting:

1. Loosen bolts and move vise jaw (Figure 19, **A**) to desired angle.
2. Tighten bolts and adjust movable vise parallel to fixed vise by loosening bolts (Figure 18, **B**), adjusting to match parallel.

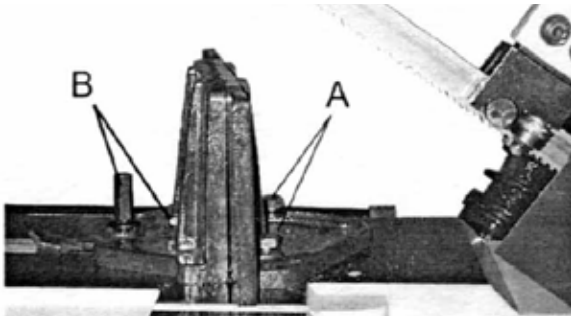

Figure 19. Vise Jaw

Lubrication

The following lubricants are used with this bandsaw:

- Gear oil: HD-150
- Hydraulic system: #32 / #68

All ball bearings are permanently lubricated and sealed. They require no further lubrication.

The hydraulics are also sealed and should not require additional fluid.

Changing Gear Box Oil

The gear box lubricant should be changed after the first 3 months of operation. Change lubricant from then on every year.

To change gear box lubricant:

1. Disconnect machine from the power source.
2. Place a collection contained below the drain plug. Drain plug is located on lower front of gear case under right wheel cover.
3. Remove drain plug with hex wrench and allow lubricant to drain completely.
4. Replace drain plug.
5. Remove filler cap and fill gear box with 50 weight gear oil until level reaches dot in middle of sight glass.
6. Replace filler cap.
7. Reconnect machine to the power source.
8. Use a light machine oil to lubricate all other moving parts as needed.

PARTS LIST

1070913

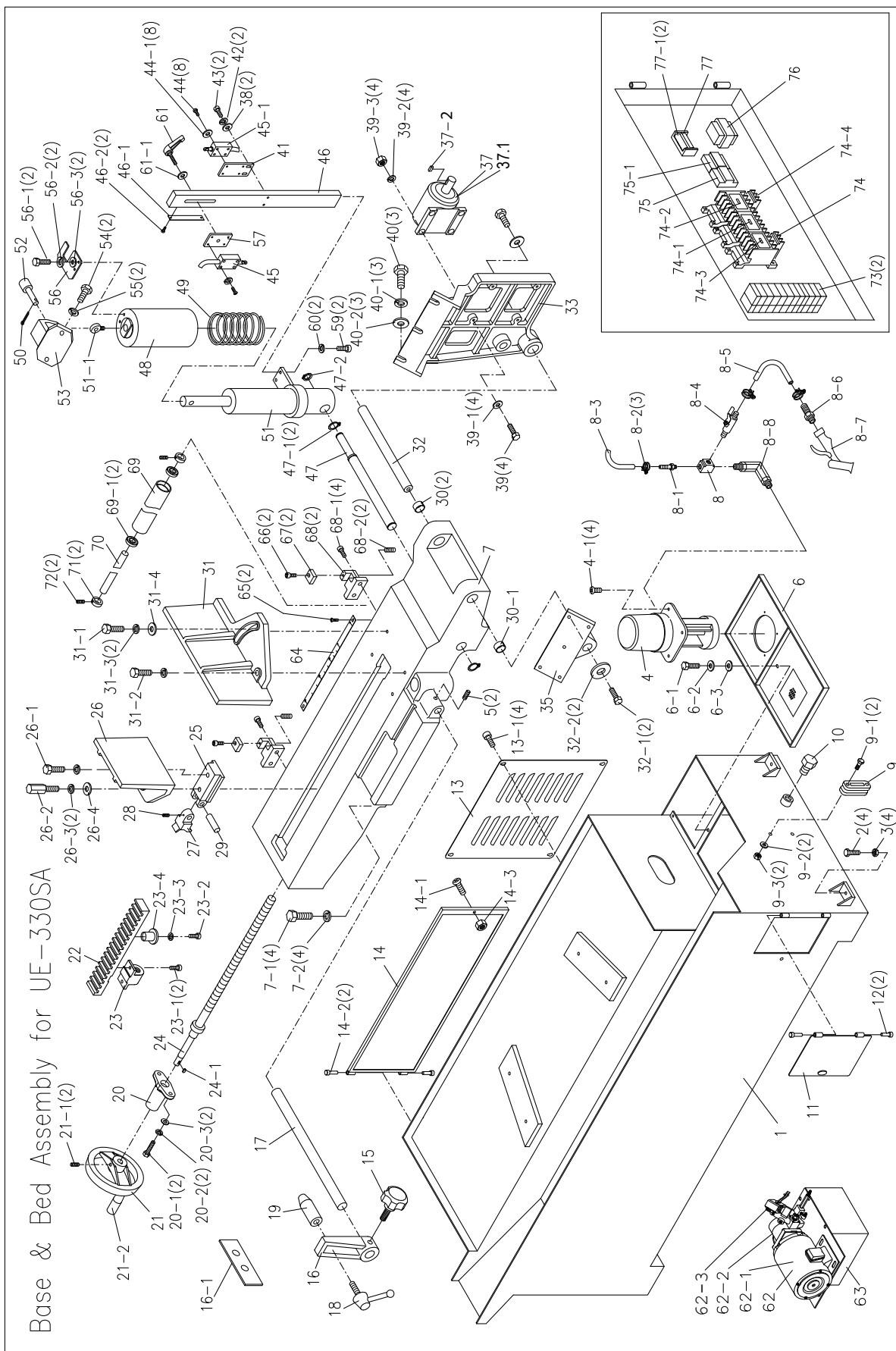

Figure 20. Parts Diagram - Sheet 1 of 2

Ref.	Description	Part Numbers	Qty
1	Base	965132901	1
2	Hex. Cap Bolt M12x65	*	4
3	Nut M12	*	4
4	Coolant Pump 1/6HP	965133001	1
4-1	Round Head Screw M6x16	*	4
5	Set Screw M8x16	*	2
6	Coolant Tank Cover	965133101	1
6-1	Round Head Screw M6x16	*	1
6-2	Spring Washer M6	*	1
6-3	Washer M6	*	1
7	Bed	965133201	1
7-1	Hex. Cap Bolt M12x50	*	4
7-2	Spring Washer M12	*	4
8	Connector	965133301	1
8-1	Hose Fitting	965133401	1
8-2	Hose Clamp	965133501	3
8-3	Hose 3/8" x 1200	965133601	1
8-4	On/Off Valve	965133701	1
8-5	Hose 3/8" x 2800	965133801	1
8-6	Hose Fitting	965133901	1
8-7	Water Gun	965134001	1
8-8	Connector	965134101	1
9	Coolant Gauge	965134201	1
9-1	Pan Head Screw M10x30	*	2
9-2	Washer M10	*	2
9-3	Nut M10	*	2
10	Drain Plug	965134301	1
11	Plate	965134401	1
12	Hinge	965134501	2
13	Plate	965134601	1
13-1	Round Head Screw M6x8	*	4
14	Electrical Box Door	965134701	1
14-1	Knob	965134801	1
14-2	Hinge	965134901	2
14-3	Nut M6	*	1
15	Lock Knob	965135001	1
16	Stop Bracket	965135101	1
16-1	Gib	965135201	1
17	Stop Rod	965135301	1
18	Lock Handle	965135401	1
19	Work Stop	965135501	1
20	Lead Screw Seat	965135601	1
20-1	Hex. Cap Screw M8x30	*	2
20-2	Spring Washer M8	*	2
20-3	Washer M8	*	2
21	Hand Wheel	965135701	1

Ref.	Description	Part Numbers	Qty
21-1	Set Screw 5/16" x 3/8"	*	2
21-2	Handle	965135801	1
22	Rack	965135901	1
23	Lead Screw Seat	965136001	1
23-1	Hex. Socket Cap Screw M8x20	*	2
23-2	Hex. Socket Cap Screw M8x20	*	1
23-3	Spring Washer M8	*	1
23-4	Bushing	965136101	1
24	Lead Screw	965136201	1
24-1	Key 6x6x25	*	1
25	Slide Bracket	965136301	1
26	Vise Jaw-Left	965136401	1
26-1	Hex. Cap Bolt M12x40	*	1
26-2	Locking Bolt M12x45	*	1
26-3	Spring Washer M12	*	2
26-4	Washer M12x35x5W	*	1
27	Rack Block	965136501	1
28	Set Screw M6x8	*	1
29	Pin	965136601	1
30	Bushing CB3020	*	2
30-1	Spacer	965136701	1
31	Vise Jaw-Right	965136801	1
31-1	Hex. Cap Bolt M16x50	*	1
31-2	Hex. Cap Bolt M16x40	*	1
31-3	Spring Washer M16	*	2
31-4	Washer M16x35x5W	*	1
32	Pivot Shaft	965136901	1
32-1	Hex. Cap Bolt M12x20	*	2
32-2	Washer M12	*	2
33	Pivot Bracket	965137001	1
35	Supporting Seat	965137101	1
37	Motor 230V, 3HP, 3PH	965137201	1
37-1	Not used		
37-2	Key 8x7x50	*	1
38	Flat Washer M6	*	2
39	Hex. Cap Bolt M10x55	*	4
39-1	Flat Washer M10	*	4
39-2	Spring Washer M10	*	4
39-3	Nut M10	*	4
40	Hex. Cap Bolt M12x50	*	3
40-1	Spring Washer M12	*	3
40-2	Washer M12	*	3
41	Switch Mounting Plate	965137301	1
42	Spring Washer M6	*	2
43	Hex. Cap Bolt M6x12	*	2

* Hardware item, available locally

Ref.	Description	Part Numbers	Qty
44	Round Head Screw M5x35	*	8
44-1	Spring Washer M5	*	8
45	Limit Switch 5101	965137401	1
45-1	Roller Limit Switch 5102	965137501	1
46	Adjusting Bracket	965137601	1
46-1	Scale	965137701	1
46-2	Rivet	965137801	2
47	Cylinder Supporting Rod	965137901	1
47-1	C-Ring S32	*	2
47-2	C-Ring S28	*	1
48	Cylinder Cover	965138001	1
49	Spring	965138101	1
50	Pin	965138201	1
51	Cylinder Assembly	965138301	1
51-1	Holder	965138401	1
52	Lock Pin	965138501	1
53	Top Mounting Plate	965138601	1
54	Hex. Cap Bolt M12x35	*	2
55	Spring Washer M12	*	2
56	Plate	965138701	1
56-1	Hex. Cap Bolt M6x12	*	2
56-2	Spring Washer M6	*	2
56-3	Flat Washer M6	*	2
57	Switch Mounting Plate	965138801	1
59	Hex. Socket Cap Screw M8x25	*	2
60	Spring Washer M8	*	2
61	Handle	965138901	1
61-1	Washer M10	*	1
62	Motor, Pump	965139001	1
62-1	Pump	965139101	1
62-2	Solenoid Valve	965139201	1
63	Hydraulic Pump	965139301	1
64	Scale	965139401	1
65	Rivet	965139501	2
66	Hex. Socket Cap Screw M6x16	*	2
67	Plate	965139601	2
68	Roller Bracket	965139701	2
68-1	Hex. Socket Cap Screw M8x20	*	4
68-2	Set Screw M10x10	*	2
69	Feeding Roller	965139801	1
69-1	Ball Bearing 6004ZZ	*	2
70	Rod	965139901	1
71	Knob	965140001	2
72	Set Screw M6x8	*	2
73	Contacts	965140101	2
74	Overload Relay (main motor)	965140201	1

Ref.	Description	Part Numbers	Qty
74-1	Magnetic Switch M2	965140301	1
74-2	Magnetic Switch M3	965140401	1
74-3	Magnetic Switch M1	965140501	1
74-4	Overload Relay (oil pump)	965140601	1
75	Relay	965140701	1
75-1	Relay	965140801	1
76	Transformer	965140901	1
77	Fuse Case	965141001	1
77-1	Fuse	965141101	2
80	Blade Wheel Cover-Right	965141201	1
80-1	Hinge	965141301	4
81	Brush Cover	965141401	1
81-1	Hex. Cap Bolt M6x12	*	2
81-2	Spring Washer M6	*	2
81-3	Flat Washer M6	*	2
81-4	Nut M6	*	2
82	Handle	965141501	2
82-1	Round Head Screw M6x16	*	4
82-2	Washer M6	*	4
83	Blade Wheel Cover-Left	965141601	1
84	Drive Wheel	965141701	1
84-1	Hex. Cap Bolt M12x20	*	1
84-2	Washer M12	*	1
84-3	Bushing	965141801	1
85	Saw Blade, 1.25" x 0.043" x 161.5"	965141901	1
86	Knob	965142001	8
87	Hex. Cap Bolt M10x30	*	4
88	Spring Washer M10	*	4
89	Hex. Cap Bolt M12x35	*	4
90	Spring Washer M12	*	4
91	Blade Guide	965142101	1
92	Saw Arm	965142201	1
93	Connector	965142301	1
93-1	Hex. Socket Cap Screw M6x20	*	2
93-2	Hose Fitting	965142401	1
93-3	On/Off Valve	965142501	2
93-4	Hose Clamp	965142601	3
93-5	Hose 5/16" x 900	965142701	1
93-6	Hose 5/16" x 1640	965142801	1
94	Gear Box	965142901	1
94-1	Key 12x8x32	*	1
94-2	Key 7x7x40	*	1
94-3	Set Screw M10x12	*	2
95	Plate	965143001	1

* Hardware item, available locally

Ref.	Description	Part Numbers	Qty
95-1	Hex. Cap Bolt M6x12	*	2
95-2	Spring Washer M6	*	2
95-3	Washer M6	*	2
96	Pulley Cover	965143101	1
97	Idle Pulley	965143201	1
98	Belt 1922V443	965143301	1
99	Variable Speeds' Governor	965143401	1
100	Cover Plate	965143501	1
100-1	Hex. Cap Bolt M8x16	*	3
100-2	Spring Washer M8	*	3
100-3	Washer M8	*	6
101	Shaft	965143601	1
101-1	Knob	965143701	1
101-2	Washer 5/16□	*	1
101-3	Nut 5/16□	*	1
101-4	Spring Washer 5/16□	*	1
102	Guide Bracket-Left	965143801	1
103	Set Screw M8x16	*	4
104	Blade Guide-Left	965143901	2
105	Blade Guide-Right	965144001	2
106	Connector (plastic)	965144101	2
106-1	Hose Clamp	965144201	2
108	Hex. Socket Cap Screw M8x30	*	4
109	Ball Bearing 608Z	*	4
110	Guide Bracket-Right	965144301	1
111	Flat Washer M8	*	4
112	Ball Bearing 6201RS	*	8
113	Sleeve	965144401	2
113-1	Sleeve	965144501	2
114	Spring Washer M8	*	4
115	Hex. Socket Cap Screw M8x45	*	4
116	Adjusting Knob	965144601	2
117	Shaft	965144701	2
118	Spring	965144801	2
119	Hex. Socket Cap Screw M16x12	*	4
120	Idle Wheel	965144901	1
121	Nut	965145001	1
122	Star Washer	965145101	1
123	Ball Bearing 30206	*	2
123-1	Ball Bearing Cover	965145201	1
124	Set Ring	965145301	1
125	Blade Guard	965145401	1
125-1	Hex. Cap Bolt M6x12	*	1
125-2	Spring Washer M6	*	1

Ref.	Description	Part Numbers	Qty
125-3	Washer M6	*	1
126	Adjusting Bracket Mount-Right	965145501	1
126-1	Adjusting Bracket Mount-Left	965145601	1
127	Lock Block	965145701	2
128	Handle	965145801	2
129	Washer M10	*	2
130	Hex. Socket Cap Screw M10x40	*	4
131	Spring Washer M10	*	4
132	Washer M10	*	4
133	Hex. Socket Cap Screw M12x25	*	2
134	Set Screw M8x10	*	4
135	Scale	965145901	1
136	Round Head Screw	965146001	5
137	Track	965146101	1
138	Bracket-Left	965146201	1
139	Hex. Cap Bolt M12x30	*	4
139-1	Spring Washer M12	*	4
140	Bracket-Right	965146301	1
141	Nut M12	*	1
142	Shaft	965146401	1
143	Spring	965146501	1
144	Pin	965146601	1
145	Rubber Pad	965146701	1
146	Stop Block	965146801	1
147	Chip Brush	965146901	1
147-1	Hex. Cap Bolt M6x12	*	1
147-2	Spring Washer M6	*	1
147-3	Washer M6	*	1
148	Bushing	965147001	1
149	Brush Bracket	965147101	1
149-1	Hex. Cap Bolt M6x16	*	2
149-2	Spring Washer M6	*	2
149-3	Washer M6	*	2
150	Electrical Box	965147201	1
150-1	Hex. Cap Bolt M6x12	*	4
150-2	Spring Washer M6	*	4
150-3	Washer M6	*	4
151	Control Panel	965147301	1
151-1	Round Head Screw M5x10	*	8
152	Relief Valve Assembly	965147401	1
153	Power Indicator Light	965147501	1
154	Start Switch	965147601	1

* Hardware item, available locally

Ref.	Description	Part Numbers	Qty
155	Stop Switch	965147701	1
156	Emergency Switch	965147801	1
157	Bow-Up Switch	965147901	1
158	Bow-Down Switch	965148001	1
159	On/Off Coolant Switch	965148101	1
160	Speed Control Switch	965148201	1
160-1	Set Screw M6x20	*	2
161	Shaft	965148301	1
161-1	Key	965148401	1
162	Handle Base	965148501	1
162-1	Handle	965148601	2
162-2	Set Screw M8x10	*	1
163	Thrust Bearing 51106	*	1
164	Washer	965148701	1
165	Set Ring	965148801	1
166	Blade Wheel Bracket Shaft	965148901	1
167	Slide Bracket	965149001	1
168	Adjusting Nut	965149101	1
168-1	Set Screw M6x8	*	1
169	Slide Plate	965149201	2
170	Hex. Socket Cap Screw M8x20	*	6
170-1	Spring Washer M8	*	6
171	Tension Bracket	965149301	1

Ref.	Description	Part Numbers	Qty
171-1	Sleeve M20x35	*	3
171-2	Spring Washer M12	*	3
171-3	Hex. Cap Bolt M12x70	*	3
172	Blade Tension Scale	965149401	1
172-1	Round Head Screw M5x10	*	2
173	Spring Supporting Shaft	965149501	1
174	Spring W=2.5mm	965149601	17
175	Flexible Set Ring	965149701	1
175-1	Set Screw M8x20	*	2
176	Limit Switch 1307	965149801	1
176-1	Round Head Screw 5/32"x1	*	2
176-2	Washer M4	*	2
176-3	Nut M4	*	2
177	Cover	965149901	1
177-1	Hex. Cap Bolt M6x12	*	2
177-2	Spring Washer M6	*	2
177-3	Washer M6	*	2
178	Rubber Clamp	965150001	1
179	Electrical Wire 0.5/2Cx430cm	965150101	1
180A	Eccentric Sleeve Assembly	965150201	2
180B	Sleeve Assembly	965150301	2

* Hardware item, available locally

PALMGREN WARRANTY

C.H. Hanson / Palmgren warrants their products to be free of defects in material or workmanship. This warranty does not cover defects due directly or indirectly to misuse, abuse, normal wear and tear, failure to properly maintain the product, heated, ground or otherwise altered, or used for a purpose other than that for which it was intended.

The warranty does not cover expendable and/or wear part (i.e. v-belts, screws, abrasives, jaws), damage to tools arising from alteration, abuse or use other than their intended purpose, packing and freight. The duration of this warranty is expressly limited to the terms noted below beginning from the date of delivery to the original user.

The Palmgren branded items carry the following warranties on parts:

All vises, clamps, positioning tables, arbor presses, tombstones, jack screws and vise accessories - LIFETIME.

All bench grinders, drill presses, tapping machines, band saws, lathes, milling machines, abrasive finishing machines and work stands - 3 YEARS.

The obligation of C.H. Hanson / Palmgren is limited solely to the repair or replacement, at our option, at its factory or authorized repair agent of any part that should prove inoperable. Purchaser must lubricate and maintain the product under normal operating conditions at all times. Prior to operation become familiar with product and the included materials, i.e. warnings, cautions and manuals.

Failure to follow these instructions will void the warranty.

This warranty is the purchaser's exclusive remedy against C.H. Hanson for any inoperable parts in its product. Under no circumstances is C.H. Hanson liable for any direct, indirect, incidental, special or consequential damages including loss of profits in any way related to the use or inability to use our products. This warranty gives you specific legal rights which may vary from state to state.

PALMGREN®

*Palmgren - a C.H. Hanson Company
2000 N. Aurora Rd., Naperville, IL 60563 U.S.A.
or call 1-800-827-3398*